

ANSI B16.36 Orifice Flanges

- Wide range of materials, including
 - ASTM A105N Carbon Steel
 - ASTM A350 LF2 Carbon Steel
 - ASTM A182 F316L Stainless Steel
- Ratings from 300 lb to 2500 lb
- Sizes from 1" Nominal Bore
- Corner Tapping Versions Available

General Description

Orifice flanges are intended for use instead of standard pipe flanges when an orifice plate or flow nozzle must be installed. Pairs of pressure tapings are machined into the orifice flange, making separate orifice carriers or tapings in the pipe wall unnecessary.

Thermocouple Instruments Ltd's orifice range of orifice flanges covers all standard sizes and ranges, and all common flange materials. Flanges are available in socket weld or weld neck form, and are typically supplied with two ½" NPT tapings in each flange. Jacking screws to ensure ease of removal of the primary flow element are provided.

Orifice plates and flow nozzles can also be supplied. See individual Product Data Sheets for more information.

Orifice flanges may also be supplied complete with bolting and gasket kits.

Materials

Thermocouple Instruments Ltd can supply orifice flanges in a wide range of standard and special materials, including:

- ASTM A105 Carbon Steel
- ASTM A350 LF2 Low Temp Carbon Steel
- ASTM A182 F316 Stainless Steel
- ASTM A182 F304 Stainless Steel
- ASTM A182 F11 1% Cr ½% Mo
- ASTM A182 F22 2¼% Cr 1% Mo

Pressure Tapings

As standard, two ½" NPT tapings are provided in each flange, one with a plug. Other thread sizes are available on request. Socket weld connections may be specified, and butt weld pipe nipples are also available. Tapings are generally 'flange' type, but corner tapings are optional.



Orifice Flange Assembly

Gaskets

Thermocouple Instruments Ltd is able to supply a range of suitable gaskets with its orifice flanges. Typical specifications are:

- 1.5 mm thick IBC ring type, non asbestos
- 3.2 mm thick spiral wound type, carbon steel outer, stainless steel inner, 316L windings with graphite filler



Studbolts and Nuts

Suitable bolting may be supplied on request. Standard materials include:

- ASTM A193 B7 and ASTM A194 Gr 2H
- ASTM A320 L7 and ASTM A194 Gr 4 or 7
- ASTM A320 B8 and ASTM A194 Gr 8

Bolting conforming to NACE is also available.



Weldneck Orifice Flange Assemblies

Weldneck orifice flanges are butt-welded into the pipeline. The inside diameter (or the schedule) of the pipe should be specified when ordering.

Weldneck orifice flanges are available in classes 300, 600, 900, 1500 and 2500. Raised face (RF) and ring type joint (RTJ) versions can be

supplied. Please refer to Product Data Sheet FM-OP/RTJA for details of orifice plates with RTJ holders.

Bolt sizes, weights and important dimensions of orifice flange assemblies are shown in the following tables.

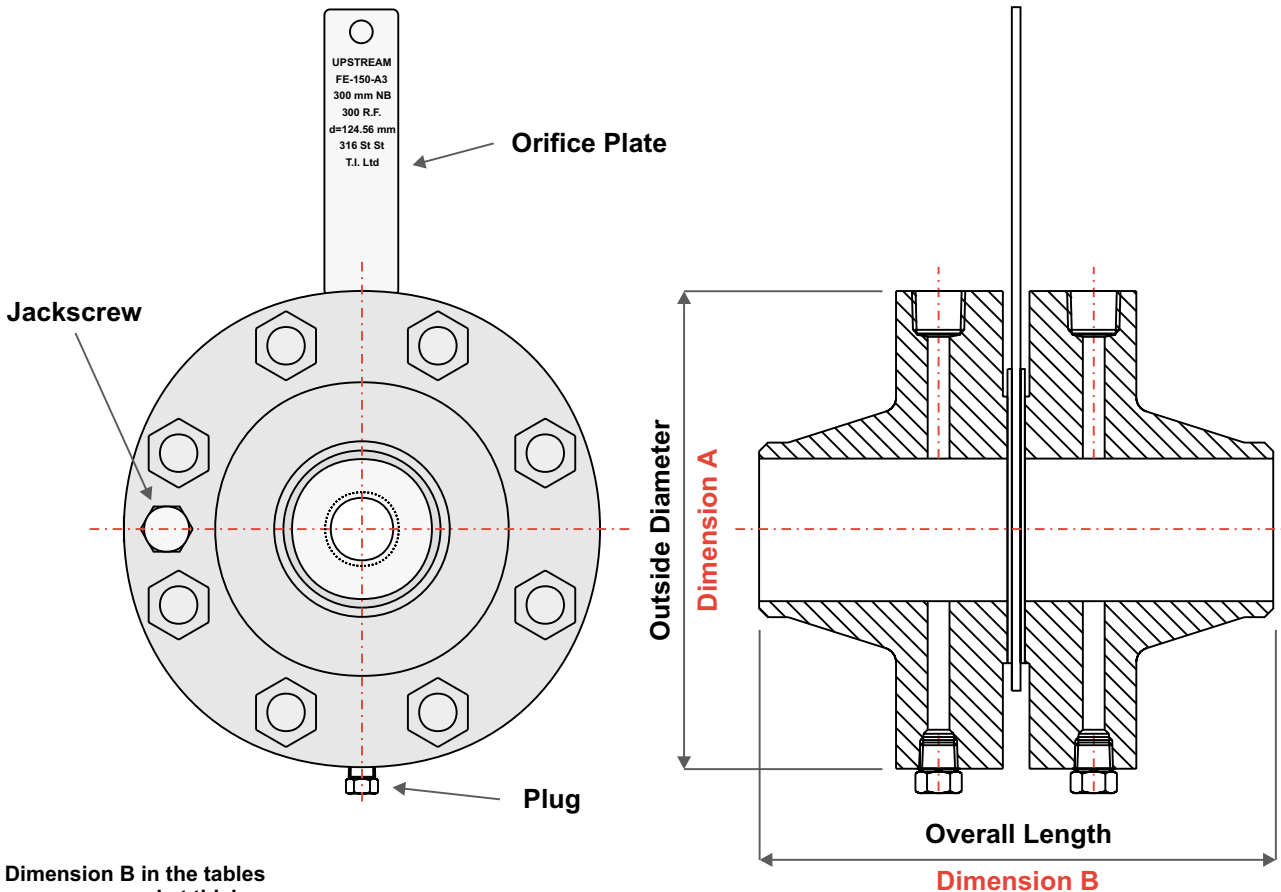

Dimension B in the tables assumes a gasket thickness of 1.5 mm and a plate thickness of 3 mm

Nominal Size		Weldneck Orifice Flanges – 300 lb RF				
		Bolts		Approx Weight (kg)	Dimensions	
mm	In	Bolt Qty	Bolt Size		B	A
25	1"	4	5/8" x 5.00"	9	171	124
40	1 1/2"	4	3/4" x 5.25"	13	178	155
50	2"	8	5/8" x 5.00"	14	178	165
65	2 1/2"	8	3/4" x 5.25"	18	184	191
80	3"	8	3/4" x 5.25"	21	184	210
100	4"	8	3/4" x 5.25"	31	190	254
150	6"	12	3/4" x 5.25"	50	206	318
200	8"	12	7/8" x 5.75"	73	229	381
250	10"	16	1" x 6.50"	100	241	445
300	12"	16	1 1/8" x 7.00"	151	266	521
350	14"	20	1 1/8" x 7.25"	207	291	584
400	16"	20	1 1/4" x 7.75"	275	298	648
450	18"	24	1 1/4" x 8.00"	341	324	711
500	20"	24	1 1/4" x 8.50"	408	330	775
600	24"	24	1 1/2" x 9.50"	604	342	914

Nominal Size		Weldneck Orifice Flanges – 600 lb RF				
		Bolts		Approx Weight (kg)	Dimensions	
mm	In	Bolt Qty	Bolt Size		B	A
25	1"	4	5/8" x 5.00"	9	171	124
40	1 1/2"	4	3/4" x 5.25"	13	178	155
50	2"	8	5/8" x 5.00"	14	178	165
65	2 1/2"	8	3/4" x 5.25"	18	184	191
80	3"	8	3/4" x 5.25"	21	184	210
100	4"	8	7/8" x 6.00"	41	209	273
150	6"	12	1" x 7.00"	82	241	356
200	8"	12	1 1/8" x 7.75"	124	273	419
250	10"	16	1 1/4" x 8.75"	208	311	508
300	12"	20	1 1/4" x 9.00"	250	317	559
350	14"	20	1 3/8" x 9.50"	-	336	603
400	16"	20	1 1/2" x 10.25"	-	362	686
450	18"	20	1 5/8" x 11.00"	-	374	743
500	20"	24	1 5/8" x 11.75"	-	387	813
600	24"	24	1 7/8" x 13.25"	-	412	940

Nominal Size		Weldneck Orifice Flanges – 900 lb RF				
		Bolts		Approx Weight (kg)	Dimensions	
mm	In	Bolt Qty	Bolt Size		B	A
25	1"	4	7/8" x 6.00"	13	171	149
40	1 1/2"	4	1" x 6.25"	18	184	178
50	2"	8	7/8" x 6.00"	29	209	216
65	2 1/2"	8	1" x 6.50"	41	215	244
80	3"	8	7/8" x 6.00"	34	209	241
100	4"	8	1 1/8" x 7.00"	59	235	292
150	6"	12	1 1/8" x 7.75"	120	285	381
200	8"	12	1 3/8" x 9.00"	204	330	470
250	10"	16	1 3/8" x 9.50"	291	374	546
300	12"	20	1 3/8" x 10.25"	405	406	610
350	14"	20	1 1/2" x 11.00"	-	431	641
400	16"	20	1 5/8" x 11.50"	-	438	705
450	18"	20	1 7/8" x 13.00"	-	463	787
500	20"	20	2" x 14.00"	-	501	857
600	24"	20	2 1/2" x 17.50"	-	590	1041

Nominal Size		Weldneck Orifice Flanges – 1500 lb RF				
		Bolts		Approx Weight (kg)	Dimensions	
mm	In	Bolt Qty	Bolt Size		B	A
25	1"	4	7/8" x 6.00"	13	171	149
40	1 1/2"	4	1" x 6.25"	18	184	178
50	2"	8	7/8" x 6.00"	29	209	216
65	2 1/2"	8	1" x 6.50"	41	215	244
80	3"	8	1 1/8" x 7.25"	58	241	267
100	4"	8	1 1/4" x 8.00"	82	254	311
150	6"	12	1 3/8" x 10.50"	186	349	394
200	8"	12	1 5/8" x 11.75"	306	432	483
250	10"	12	1 7/8" x 13.50"	500	514	584
300	12"	16	2" x 15.00"	764	571	673
350	14"	16	2 1/4" x 16.25"	-	603	749
400	16"	16	2 1/2" x 17.75"	-	628	826
450	18"	16	2 3/4" x 19.75"	-	660	914
500	20"	16	3" x 21.50"	-	717	984
600	24"	16	3 1/2" x 24.50"	-	819	1168

Slip-On Orifice Flange Assemblies

Slip-on orifice flanges are designed to slip over the pipeline before welding.

Slip-on orifice flanges are available in class 300, with a raised face (RF).

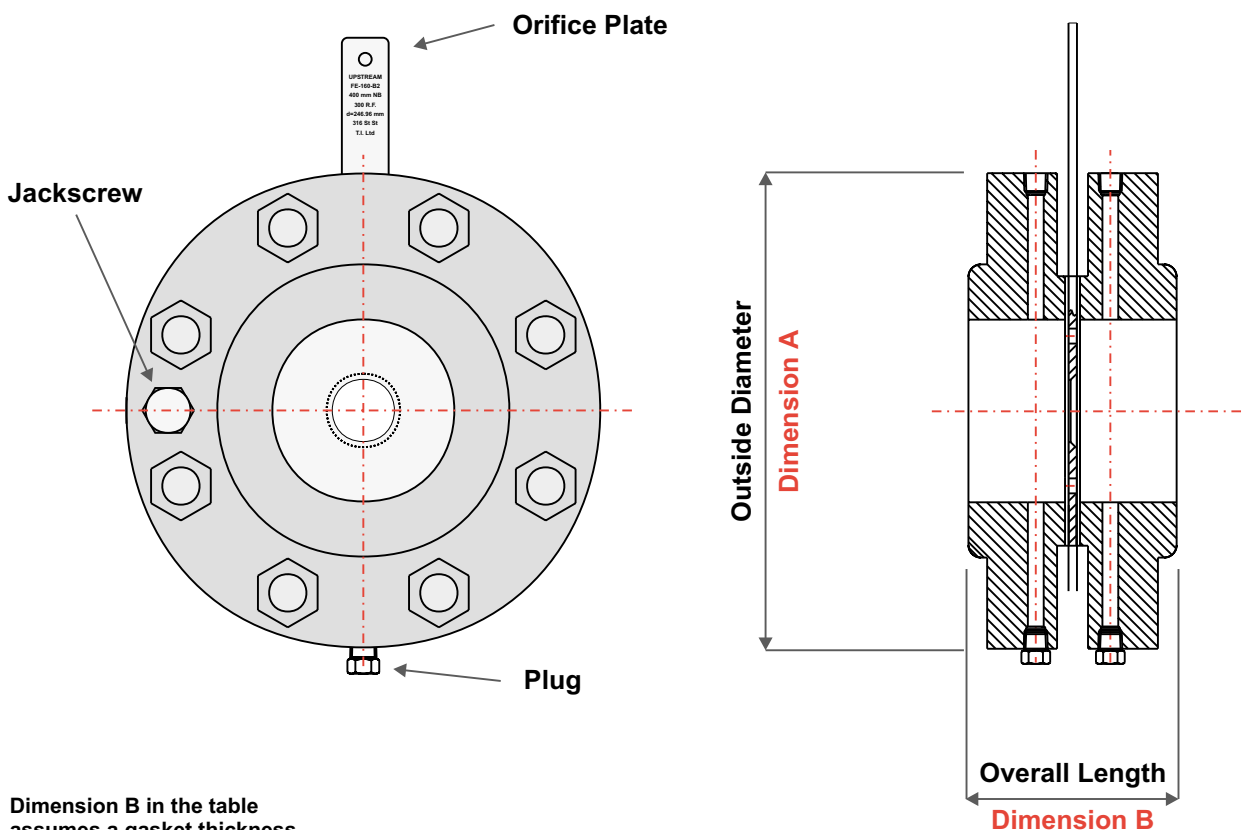

Dimension B in the table assumes a gasket thickness of 1.5 mm and a plate thickness of 3 mm

Nominal Size		Slip-On Orifice Flanges – 300 lb RF				
		Bolts		Approx Weight (kg)	Dimensions	
mm	In	Bolt Qty	Bolt Size		B	A
25	1"	4	5/8" x 5"	7.5	102	124
40	1 1/2"	4	3/4" x 5.25"	9.3	102	155
50	2"	8	5/8" x 5.00"	11.5	105	165
65	2 1/2"	8	3/4" x 5.25"	15	108	191
80	3"	8	3/4" x 5.25"	19	111	210
100	4"	8	3/4" x 5.25"	29	114	254
150	6"	12	3/4" x 5.25"	50	114	318
200	8"	12	7/8" x 5.75"	65	130	381
250	10"	16	1" x 6.50"	91	139	445
300	12"	16	1 1/8" x 7.00"	133	152	521
350	14"	20	1 1/8" x 7.25"	177	158	584
400	16"	20	1 1/4" x 7.75"	240	171	648
450	18"	24	1 1/4" x 8.00"	323	184	711
500	20"	24	1 1/4" x 8.50"	360	197	775
600	24"	24	1 1/2" x 9.50"	555	219	914