

Restriction Orifice Plates

- Manufactured generally to BS EN ISO 5167
- Wide range of materials
- Proven technology
- Suitable for most pipe sizes
- Orifice sizing on request

General Description

Restriction orifice plates can be used as a simple pressure reducing device, or to limit the flow rate in a pipeline. They are designed to slip between pipe flanges. Versions to suit RTJ type flanges are available.

Dimensions

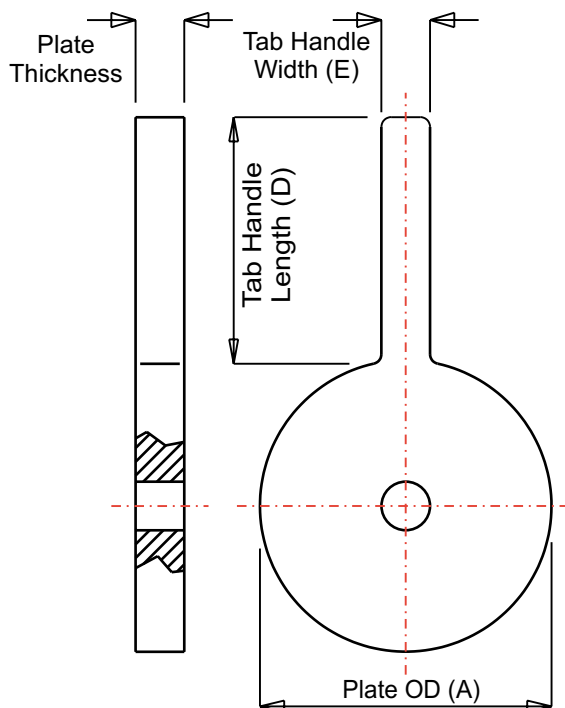

The outside diameter of the orifice plate is equal to the bolt circle diameter of the connecting flanges minus the diameter of the bolt. This ensures that the plate is centred accurately in the line.

Plate thicknesses depend on line size and differential pressure, and should be sufficient to prevent the plate from bending under operating conditions. Recommended plate thicknesses are shown on the graph on page 2.

Thermocouple Instruments Ltd standard plate dimensions are shown in Figure 1. Orifice plates can be made in accordance with customer drawings as required.



Restriction Orifice Plate

Materials

Standard material grades include 316 Stainless Steel, 304 Stainless Steel, 310 Stainless Steel, Hastelloy® C276, Hastelloy® B3, Duplex Stainless Steel, Super Duplex Stainless Steel, Monel® 400, Carbon Steel, Titanium, Incoloy® 800, Incoloy® 825, Inconel® 600, Inconel® 625, Tantalum, PTFE and PVDF.

Please contact the sales office for other grades.

Orifice Bore Sizing

Orifice calculations are performed generally in accordance with the formulae detailed in RW Miller's Flow Measurement Handbook, when requested.

Refer to Technical Data Sheet TD-FM/QU1A for data required for calculation.

The Thermocouple Instruments Ltd restriction orifice sizing program, ROCalc, is also available for purchase. Refer to Product Data Sheet FM-SW/ROCA.

RTJ Type Restriction Plates

Restriction orifice plates to mount between RTJ type flanges are also available, in one or two piece designs, and in a wide range of materials. For further details, please refer to Product Data Sheet FM-OP/RTJA.

Recommended Plate Thickness

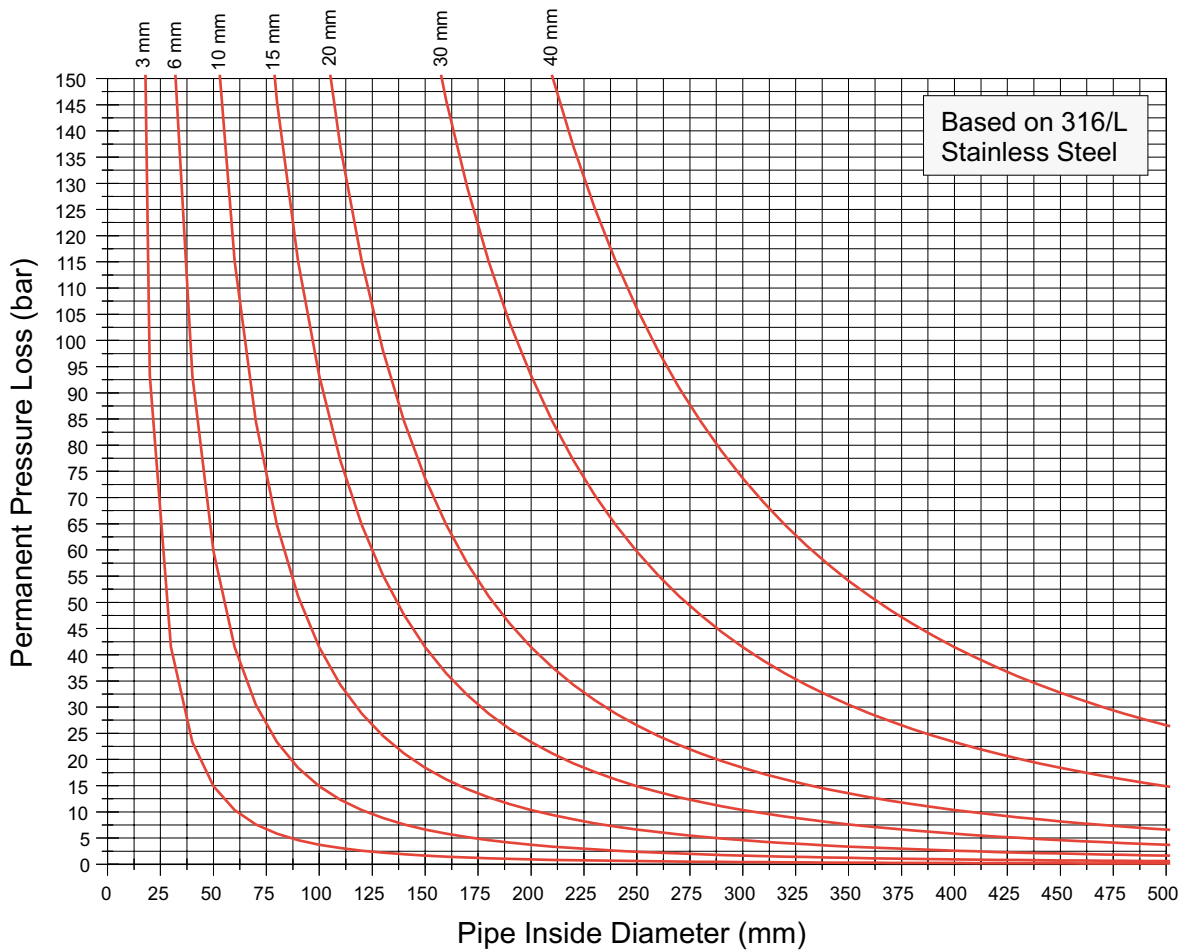

NOMINAL LINE SIZE		150 LB			300 LB			400 LB			600 LB			900 LB			1500 LB			2500 LB		
mm	IN	A	D	E	A	D	E	A	D	E	A	D	E	A	D	E	A	D	E	A	D	E
15	1/2"	47.6	125	25	54	125	28	54	125	28	54	125	28	63.5	125	32	63.5	125	32	69.9	125	32
20	3/4"	57.2	125	32	66.7	125	32	66.7	125	32	66.7	125	32	69.9	125	32	69.9	125	32	76.2	125	32
25	1"	66.7	125	32	73	125	32	73	125	32	73	125	32	79.4	125	32	79.4	125	32	85.7	150	32
30	1 1/4"	76.2	125	32	82.6	125	32	82.6	125	32	82.6	125	32	88.9	125	32	88.9	125	32	104.8	150	32
40	1 1/2"	85.7	125	32	95.3	125	32	95.3	125	32	95.3	125	32	98.4	125	32	98.4	125	32	117.5	150	32
50	2"	104.8	125	32	111.1	125	28	111.1	125	28	111.1	125	28	142.9	150	32	142.9	150	32	146	150	32
65	2 1/2"	123.8	125	32	130.2	125	32	130.2	125	32	130.2	125	32	165.1	150	32	165.1	150	32	168.3	150	32
80	3"	136.5	125	32	149.2	125	32	149.2	125	32	149.2	125	32	168.3	150	32	174.6	150	32	196.9	150	32
100	4"	174.6	150	32	181	150	32	177.8	150	32	193.7	150	32	206.4	150	32	209.6	150	32	235	150	32
125	5"	196.9	150	32	215.9	150	32	212.7	150	32	241.3	150	32	247.7	150	32	254	150	32	279.4	175	32
150	6"	222.3	150	32	250.8	150	32	247.7	150	32	266.7	150	32	288.9	150	32	282.6	150	32	317.5	175	32
200	8"	279.4	150	32	308	150	32	304.8	150	32	320.7	150	32	358.8	175	32	352.4	175	32	387.4	175	32
250	10"	339.7	150	32	362	150	32	358.8	150	32	400	150	32	435	175	32	435	175	32	476.3	200	32
300	12"	409.6	150	32	422.3	150	32	419.1	150	32	457.2	150	32	498.5	175	32	520.7	175	32	549.3	200	32
350	14"	450.9	150	32	485.8	150	32	482.6	150	32	492.1	150	32	520.7	175	32	577.9	175	32	-	-	-
400	16"	514.4	150	32	539.8	150	32	536.6	150	32	565.2	150	32	574.7	200	32	641.4	200	32	-	-	-
450	18"	546.1	175	32	593.7	175	32	587.4	175	32	609.6	175	32	635	200	32	701.7	200	32	-	-	-
500	20"	603.3	175	32	650.9	175	32	644.5	175	32	679.5	175	32	695.3	200	32	752.5	200	32	-	-	-

Figure 1 - Standard Orifice Plate Dimensions for ANSI RF Flanges

Thermocouple Instruments Limited

Pentwyn, Cardiff, CF23 7XJ, UK
 Tel: (+44) 029 20734121 Fax: (+44) 029 20734040
 Internet: <http://www.thermocouple.co.uk>
 E-mail: thermocouple@thermocouple.co.uk

All Rights Reserved. © Copyright 2000 Thermocouple Instruments Ltd.

Incoloy, Inconel and Monel are trademarks of INCO Alloys International Inc.
 Hastelloy is a trademark of Haynes International Inc.