

AC STATION

Multifunction Programmable Controllers

- Multiloop controller
 - Micro PLC
 - Process computer
- in just one instrument**

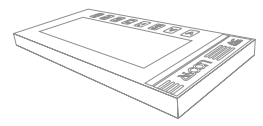
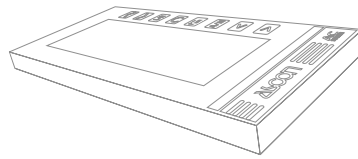

E

ISO 9001 Certified

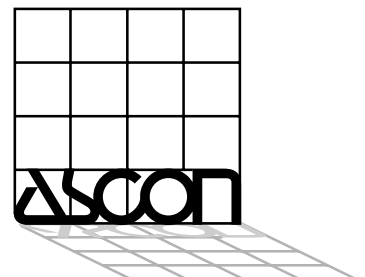

Control and automation in the process and manufacturing industry demands increasing flexibility, a high level of integration of control functions and user friendly Human Machine Interface.

AC STATION controllers represent the single most effective and innovative solution to these demands. One AC STATION instrument can perform:

- Data acquisition and monitoring
- Regulation and control
- Complex mathematical functions
- Logic and sequencing
- Alarm functions
- Local monitoring of process data, control functions, alarms and events
- Automatic and manual commands.

This flexibility dramatically reduces: control cubicle size, the number of components required and the engineering time to develop an automation system.

- 4...8 analogue inputs
- 4...8 analogue outputs
- 8..32 digital inputs
- 8..32 digital outputs
- RS485 serial link, Modbus and J-bus Protocol (slave)
- Peer-to-Peer communications



A single key stroke to select one of 12 preprogrammed control strategies stored in the instrument's library.

Several bargraph, trend, alarm and menu pages displayed on a long life, clear, high-resolution LCD display.

Free, easy and quick programming of the required control strategy via a PC, thanks to a block structured architecture supported by AC-PROGRAPH, a graphic configuration software tool.

Extensive Hardware

8 analogue inputs,
4 isolated analogue outputs (expandable to 8)
8 digital inputs +8 digital outputs (expandable to 32+32),
3 serial ports
and 1 high speed LAN port.
Power supply for external transmitters (300mA).

Multifunction

Up to 4 control loops with advanced PID, self-tuned by the intelligent and interactive "InTune" algorithm. Logic and sequential as well as complex mathematic functions.

Historical and real time trends. Alarm handling, Auto/Man Station, variable monitoring, etc.

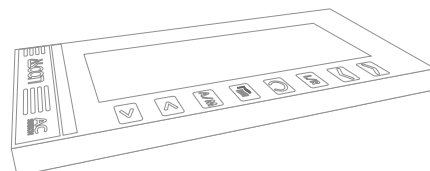
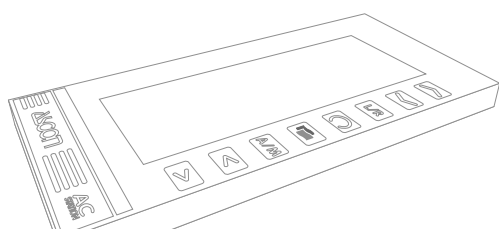

Freely programmable

Wide library of function blocks. The graphical, user-friendly AC-PROGRAPH software, running on a standard PC, allows to design the most suitable control strategy to match the requirements of any process. Programming can be carried out by the user himself with a guarantee of secrecy and safety for the application.

Easy to use

There are 12 resident preprogrammed control strategies selectable from the keyboard. Remote tech-support. High resolution graphic panel to display in a simple, clear and complete manner: interactive guided menus, bargraph pages, trends, alarms, commands, . . . Three different levels of access for instrument programming, parametrization and normal operation.

Very compact and light

72 x 144 DIN format, depth 260mm., weight 1,6 kg.

From SLC to mini DCS

The extensive hardware, the powerful software, the Peer to Peer communications, associated with its simplicity of use, permit the employment of these instruments as a simple SLC, as a mini DCS and also as part of a DCS whenever it is integrated in a complex system.



Guaranteed and Certified

Designed in accordance with IEC and EN standards, AC controllers are available with the CE, UL and C/UL marks. Together with all the other ASCON products, the AC controllers are manufactured in accordance with ISO9001/EN9001 Quality Assurance Management System.

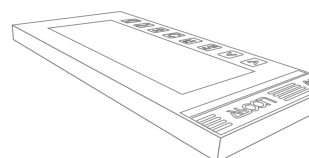
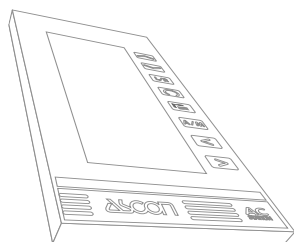
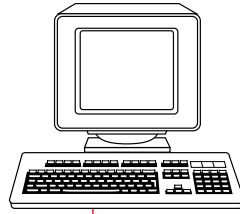

Display

Long life, clear and high resolution (128x320 pixels) LCD display. Size 40x104 mm. Extended operating temperature range (0...55°C) and adjustable contrast guarantee an high level of visibility even in harsh environments.

Pages

Several pre-formatted pages are available to display numerical values, bargraphs, trends, alarms, menus.... Designed to match a wide range of requirements, they can be customized.

Menus

Self-explaining menus allow an easy access to sub-menus and commands, structured in a hierarchical way.

Three operational levels

To simplify normal operations and to protect the most critical commands, the start-up engineer and the plant manager can set passwords to access different operational levels.

The programming of the control strategy can be done in a guided manner from the keyboard or with the help of a PC.

Your Personal Process Information System

Several pre-formatted "customizable" pages

Easy to understand, guided, interactive menus

Three levels of operation with differentiated access

Auto-diagnosis

To test all the hardware resources, a complete diagnostic program

can be activated on the instrument, without the need of any external equipment.

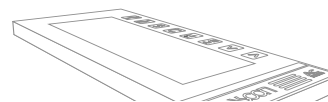
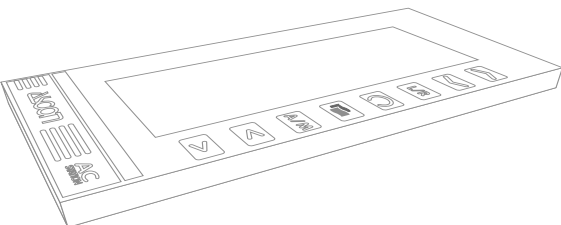
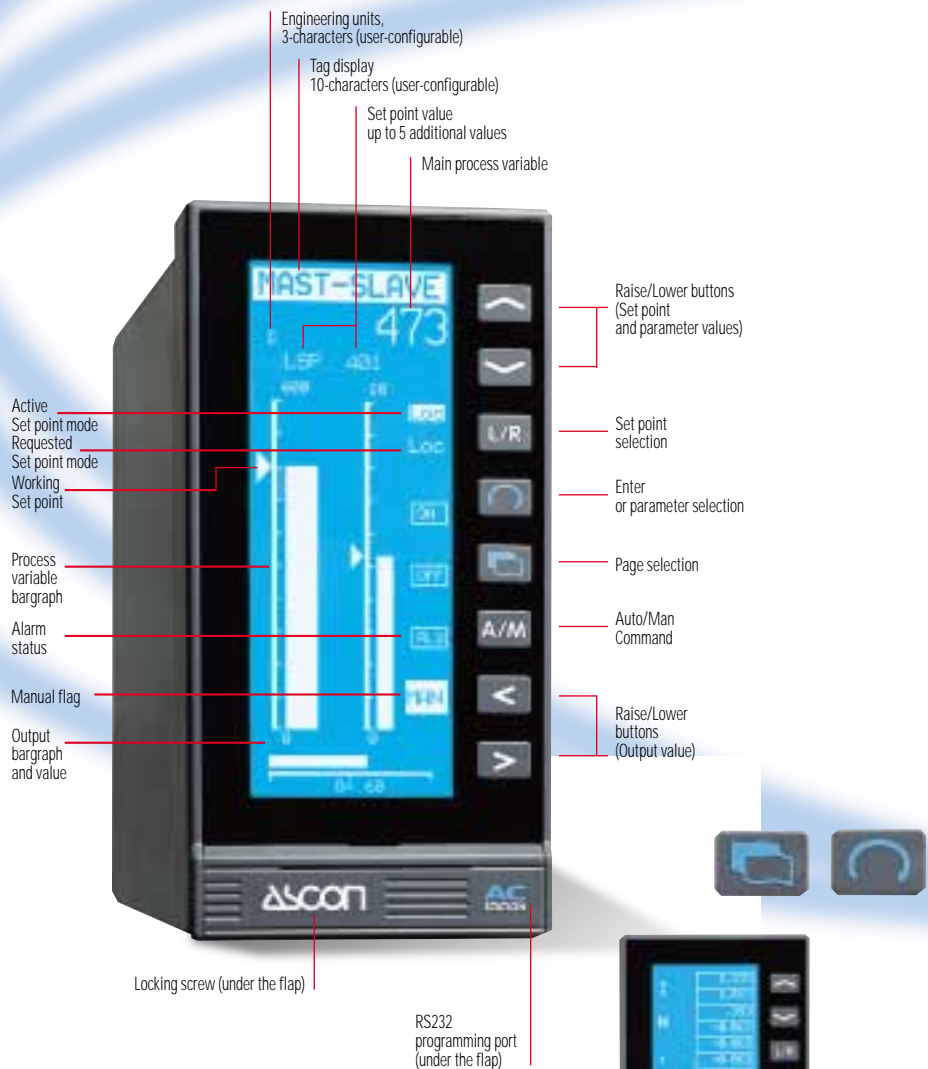

in man-machine interface



Bargraph



Trend



Alarms



Operator level

The operator can access bargraph, trend, alarm and command pages. In addition, depending on the entered password,

he can access permitted command and modification functions, such as Set point management, Auto/Manual command.....



Project engineer level

The project engineer sets-up the control functions choosing from the standard preprogrammed strategies

or perhaps partially redesigning one of them. He can also build-up a completely new control strategy.

Start-up level

The start-up engineer can access all the configuration parameters of the function and control blocks. He also defines the password and access codes for the operator.



Launching "In-Tune"



PID parameters...



Control Strategy selection



Function block menu



Function block selection

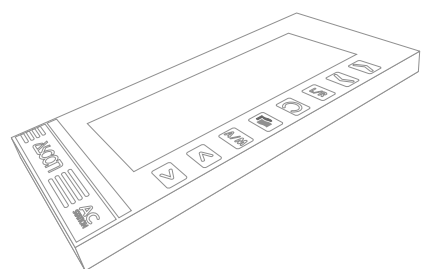



Extensive library of elementary and complex function blocks
 PC based programming software running under Microsoft Windows
 Disk archiving of control strategies and parameters



Display pages
 Bargraphs (1, 2, 3 or 4)
 Trends
 Alarms, logic status and signal forcings
 Command panel
 Programmer
 Real-time clock
 Guided and interactive menus
 Parameters
 Others, freely programmable

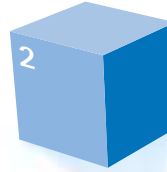

Input conditioning
 Linearization Table
 Polynomial linearization
 Thermocouple output linearization
 RTD output linearization
 Scale changes
 Engineering units
 Square Root
 Digital filter
 Temperature compensation
 Pressure compensation

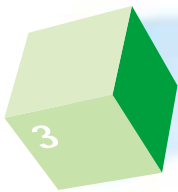

Mathematical functions
 Addition - Subtraction
 Multiplication - Division
 Absolute value
 Square Root
 Power
 Sine - Cosine
 Exponential - Derivative
 Nat.-Common logarithm



Logic functions
 AND/OR/EXOR/NOT
 Flip-flop
 Select - deselect logic



Complex expressions
 freely configurable
 i.e. Koch's equation of state

$$v = \frac{RT}{P} - \frac{A}{\left(\frac{T}{100}\right)^{2.82}} - p^2 \left[\left(\frac{B}{100}\right)^4 \cdot \left(\frac{C}{100}\right)^{31.4} \right]$$

Comparators, selectors
 Max min selection
 Limiter
 Rate limiter
 Analogue - digital multiplexer



Protection
 Different access
 for project engineer,
 start-up engineer and operator
 Set Point, Output, Input limits
 Keyboard lock
 Auto-diagnosis
 Remote tech-support

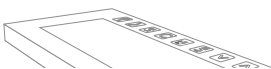
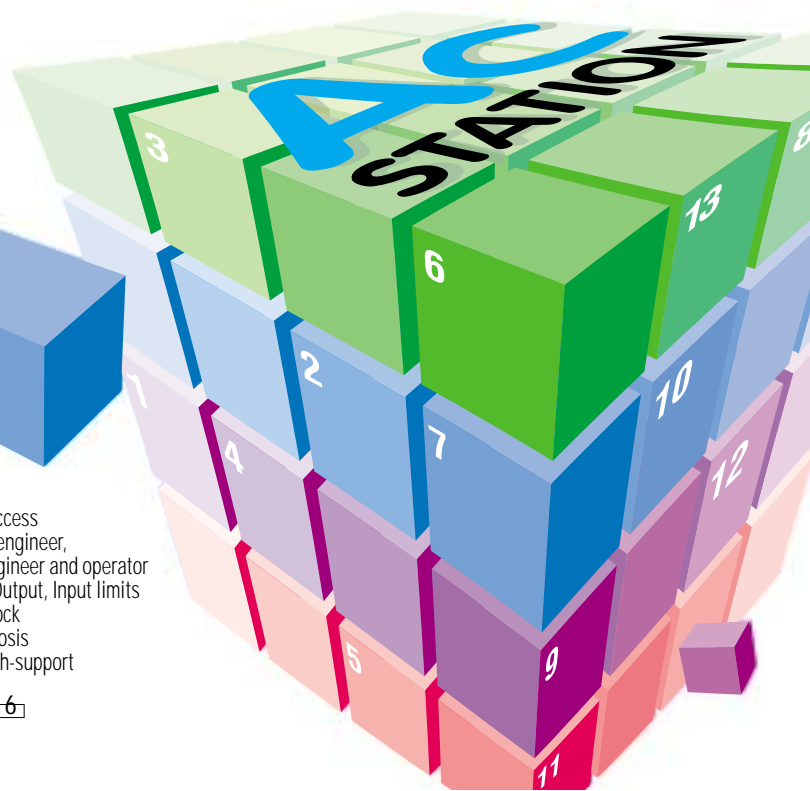

your own control strategy



Alarms
Absolute
Deviation
Rate



Set point Management
Local-Remote,
Safety Set point
4 stored values
4 priority levels



Analogue outputs
Min max Limits
Rate limits
Safety value
Tracking
Hold
Min max signal forcings
Heat/Cool outputs



The AC multifunction controller provides an extensive library of analogue and digital function blocks, starting from the very simple "AND - OR -..." module up to the very sophisticated ones such as, i.e., the mathematic module solving any level of complex functions.



Control
Advanced PID algorithm with 2 degrees of freedom for a correct control response during both Set point and load changes.
Intelligent tune "InTune"
Gain scheduling
Bumpless
Feed forward
PID saturation signalling



Timers and counters
Totalizers
Counters with reset
4 types of timers
Powerful scheduler



Sequence
Up to 4 independent sequences
16 x 4 selectable sequences
Up to 100 steps per sequence

The use of this library is made easy by the AC-PROGRAPH graphic software running under Microsoft Windows, which allows to build-up a control strategy by simply selecting, positioning and configuring the function blocks on the work-sheet, and drawing the required connections. The powerful software allows to employ the AC controller as a micro DCS. However, pre-configured standard strategies, that match the most common requirements, are supplied in the AC controller and are selected by the instrument keyboard.

The configuration of the function blocks and all the parameters of the controller can be inserted via the frontal keyboard or downloaded from a PC. It is possible to upload them with a PC and store them on disk for archiving or for security purposes.

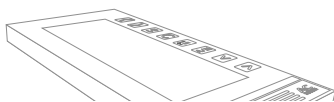
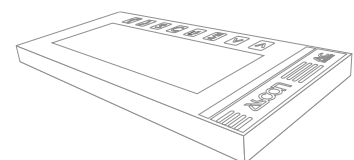
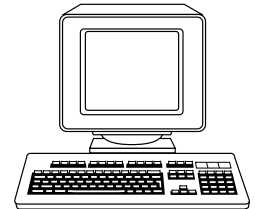

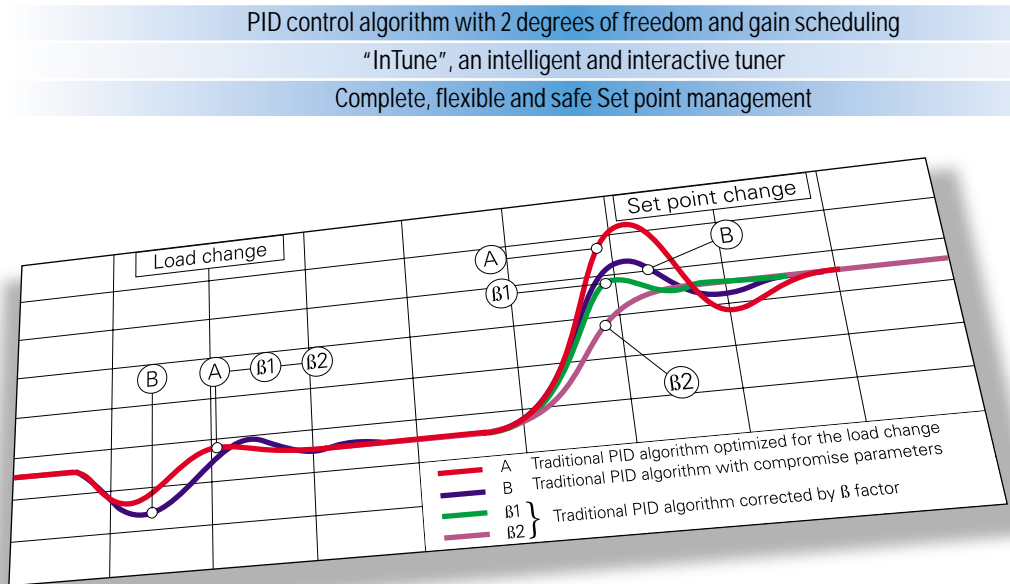
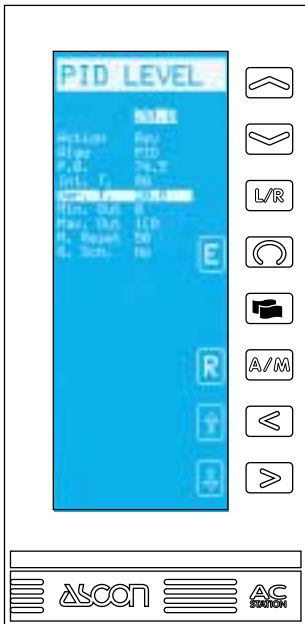

PID algorithm with 2 degrees of freedom

The traditional PID optimized on disturbances of the process, does not respond in a satisfactory manner

to changes of the Set point and vice-versa. With the 2 degrees of freedom PID designed by ASCON, it is not necessary to descend to compromise responses because it is possible to optimize the two responses

separately in a simple manner acting on a parameter (2nd degree of freedom).

Gain scheduling

For applications on processes with non linear characteristics or those strongly influenced by external agents, the Gain scheduling function permits the modification of PID parameters to fit the different operating conditions. The law can be defined in a tabular form or with a mathematical expression, even a complex one.

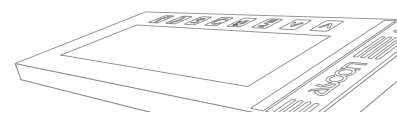
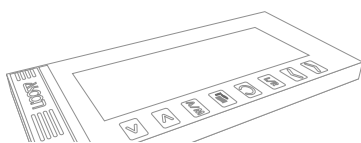
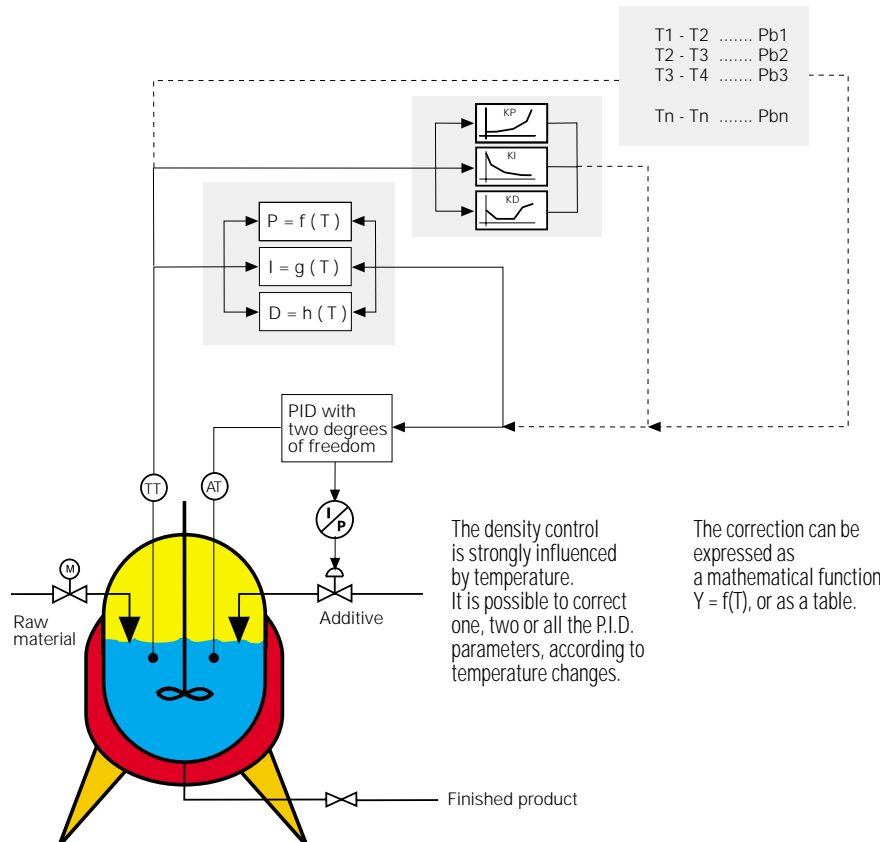

"In Tune"

- Intelligent : on the basis of the selected algorithm, PID, PI or simply P, the control parameters are calculated with the method known as "natural frequency". Tuning can occur at a Set point change or during process steady conditions. The method is based on the analysis of the response of the process to small disturbances



introduced by the controller itself, to calculate the natural frequency of the process. The result is a big improvement compared with conventional Ziegler and Nichols method.
 - Interactive : the method assists the operator displaying the behaviour of the process during the tuning phase and presenting, at the end of the procedure, the old parameters and the

new calculated ones. The operator can select between an automatic revision of the new parameter values, or a manual re-entry after approval.

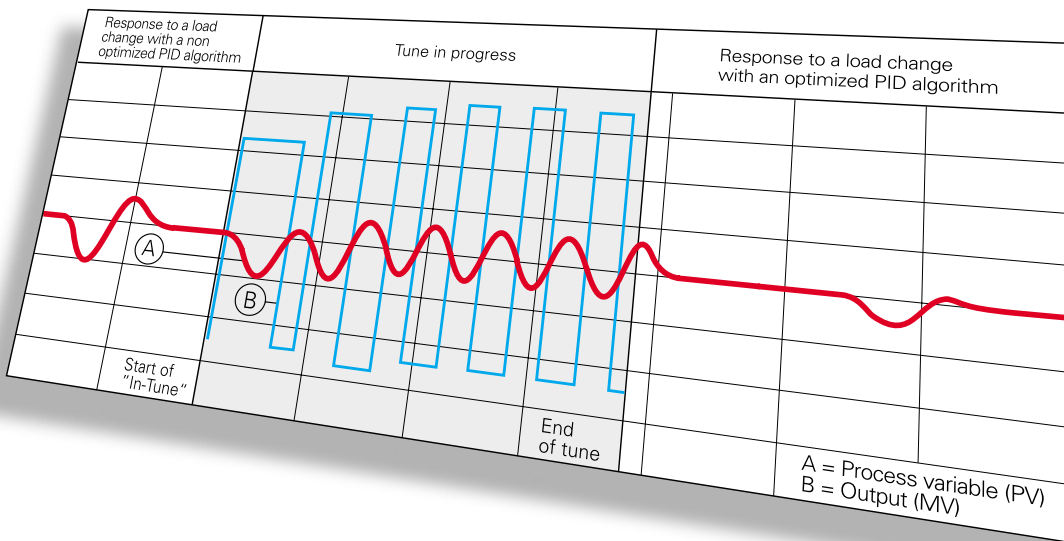

Set point management

- Complete: in addition to Local Set point entered through the instrument

keyboard, the following stored Set points values are available: Analog Remote Set point, Computer Remote

Set Point and Safety Set Point.
 - Flexible: the selection of the working Set point can be done via the keyboard, internal logics, logic inputs or serial communications. The selection of the safety Set point has the highest priority.
 - Safe: the controller allows to assign different levels of priority for the activation of the working Set point. This avoids conflict of access for simultaneous requests and the risk of unwanted unauthorised changes.

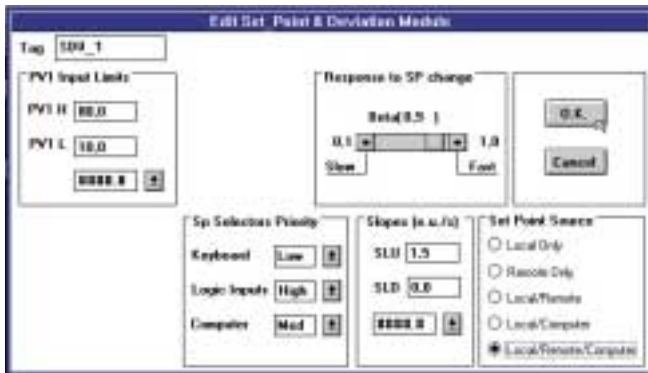

4 Communications Ports grant to the AC controllers unequal characteristics of versatility and expandability as well as the ability to be integrated into larger control systems.

- For supervision and remote-tech support
- For resources sharing and/or LAN integration
- For the expansion of hardware resources and for back-up
- For programming

MODBUS/J-bus • RS485 MODBUS/J-bus • RS485 MODBUS/J-bus • RS485 MODBUS/J-bus • RS485 M



Programming



GRAMMING • PROGRAMMING • PROGRAMMING • PROGRAMMING • PROGRAMMING • PRO

PEER • PEER TO PEER • PEER TO PEER • PEER TO PEER • PEER TO

RS485 Modbus/J-bus Communications Port
It permits total supervision via a PC or a Host computer. Up to 31 controllers of the AC family can be supervised on the same line. Communication rates are up to 19.2K baud.

AUTO LINK™ supervisory software package developed by ASCON for standard PCs, allows to centralize all the process operations and to supply remote-tech support for the plant.

RS232 Programming Port
A frontal connector is available to download the control strategy, or simply configure function blocks and insert parameters with the aid of a PC, in a very simple and quick manner.

The port also allows parameter and program uploading into a PC, in order to save instrument configuration files.

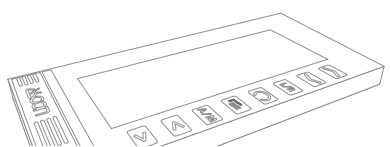

with 4 communications lines



RS485 MODBUS/J-bus • RS485 MODBUS/J-bus • RS485 MODBUS/J-bus • RS485 MODBUS/J-bus • RS485 MODBUS/J-bus



EXPANSION • I/O EXPANSION • I/O EXPANSION

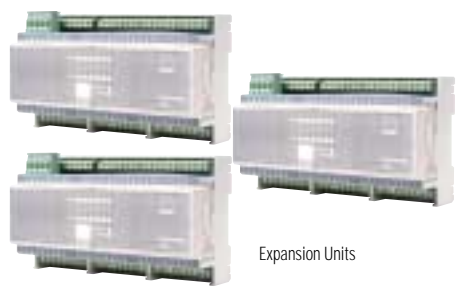

Expansion Units

PEER • PEER TO PEER • PEER TO PEER • PEER TO PEER • PEER TO PEER • PEER TO PEER

RS485 Port for Expansion Units
 AC20 and AC30 controllers support the connection of up to 3 Expansion units to increase the number of I/O channels:

analog output can be increased from 4 to 8 and digital I/Os from 8 to 32 channels.

Peer-to-Peer communications
 This port, available as an option for AC20 and AC30 controllers, allow to share hardware and software resources of a set of instruments,

to build up a small distributed integrated system (mini DCS). Supervisory functions can still be provided using RS485 Communications Port.

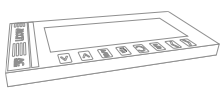

Within the family of "AC Station" controllers, the AC10 model represents the ideal solution for many common control problems such as single and multi loops, ratio, cascade, etc.

Hardware

The AC10 Controller is equipped with :

- 4 analogue inputs for variables to be controlled, recorded or monitored.
- 4 analogue outputs for control and/or retransmission.
- 8 opto-isolated digital inputs: to enable Remote, Safety or stored Set points; to force to Manual operating mode; to activate special functions like Tracking, Bias, Feed-forward, etc.
- 8 opto-isolated digital outputs for commands and/or alarms.

Communications

A RS485 serial port with Modbus and J-bus protocols permits connection to a PC for supervision, parametrization and remote-tech support.
A RS232 serial port permits, through the PC, the downloading, uploading and saving of parameters.

- Up to 4 Independent loops
- 4 analogue inputs + 4 analogue outputs
- 8 digital inputs + 8 digital outputs
- RS485 serial link with Modbus / J-bus protocol
- 12 preprogrammed control strategies selectable via the instrument keyboard



Control strategy

Description	PID	Set Rem	Set Mem	F.F.	Tracking Int.	Ext.	MAN	Ysaf.	Ymin	Ymax	Analogue. Retransm	Alarms
1 Loop A	1	1	1	-	1	-	1	-	-	-	1	4
1 Loop B	1	1	3	1	1	1	1	-	1	1	3	8
1 Loop C	2	1	3	-	1	1	1	-	1	1	2	6
2 Loops A	1+1	1+1	1+1	-	1+1	-	1+1	1+1	-	-	1+1	4+4
2 Loops B	1+1	1	1+1	1	1+1	-	1+1	1+1	1	1	2	4+4
2 Loops C	2+1	1	1+1	-	1+1	1	1	-	1	1	1	6+2
Ratio	2	1+1	1	-	1+1	-	1+1	1+1	1	1	-	7+1
Cascade	2	1	1	-	1+1	-	1	-	-	-	1+1	4+4
Override	2	1+1	1+1	-	1	-	1	1	1	1	1+1	5+3
4 Loops	4	-	-	-	1x4	-	1x4	1x4	-	-	-	2x4
4 Indicators	-	-	-	-	-	-	-	-	-	-	1x4	2x4
A/M Station	-	-	-	-	2	2	2	2	2	2	2	-

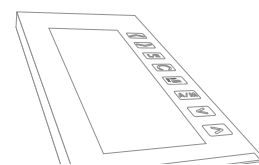
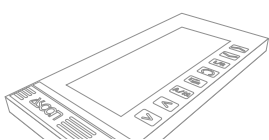

Multiloop Controller

Interface and Programming

Thanks to an easy to understand, guided and interactive menu, the man-machine interface (MMI) is very easy, clear and safe. All the functions and the displays are activated in a simple manner using the keys on the front panel. One of the most important characteristics of this controller is the availability of a library with 12 preprogrammed Control Strategies (CS) stored in its memory (see table). After having selected the required Control Strategy, by means of simple and guided operations on the front panel, the instrument presents only the related configuration parameters.

The great flexibility and its exceptional adaptability to the frequently changing control requirements of industrial processes, make the AC10 controller ideal for many applications:

from food to chemical/ pharmaceutical industry, from power generation to environmental control, from glass to cement industry, etc.

Some applications

Cascade control loop

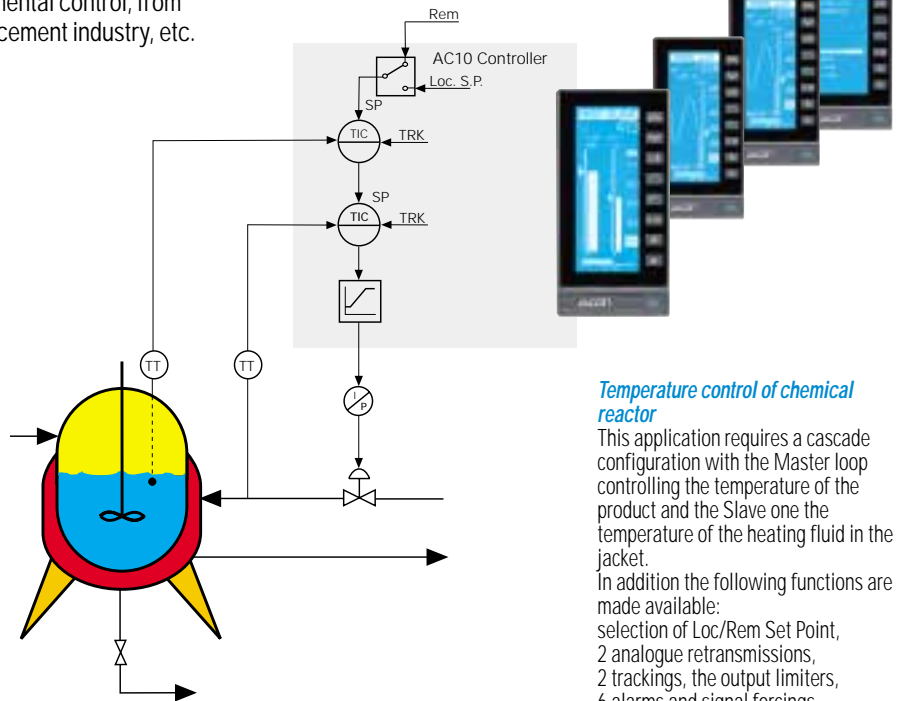

Temperature control of chemical reactor

This application requires a cascade configuration with the Master loop controlling the temperature of the product and the Slave one the temperature of the heating fluid in the jacket. In addition the following functions are made available: selection of Loc/Rem Set Point, 2 analogue retransmissions, 2 trackings, the output limiters, 6 alarms and signal forcings.

4 Independent Loops

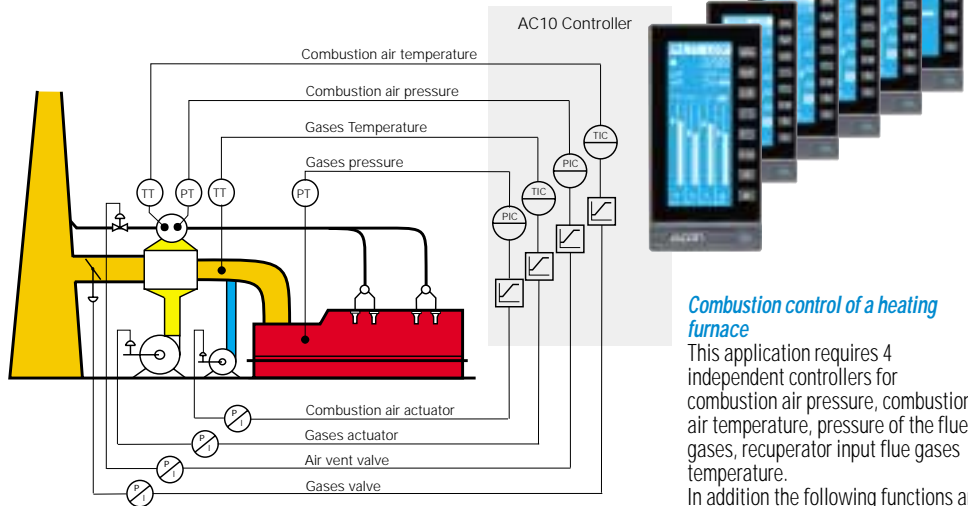

Combustion control of a heating furnace

This application requires 4 independent controllers for combustion air pressure, combustion air temperature, pressure of the flue gases, recuperator input flue gases temperature. In addition the following functions are made available: 4 trackings, 4 limits on the outputs, 8 alarms and 4 signals forcings.

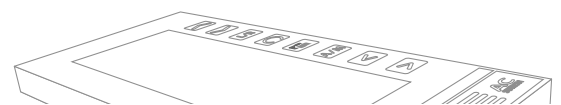

Up to 8 analogue inputs + 8 analogue outputs - Up to 32 digital inputs + 32 digital outputs

RS485 with Modbus and J-bus protocol - Peer-to-Peer communications

Multiple resident control strategies and an extensive library of function blocks for programming the required one with a PC

The extensive and expandable hardware, the 4 communications ports, but mostly the complete freedom in programming Control Strategies, make the AC20 an advanced and powerful controller, suitable for every process, even the most complex.

Expandable hardware

The basic AC 20 Controller is equipped with:
 8 analogue inputs,
 4 analogue outputs,
 8 opto-isolated digital inputs
 8 opto-isolated digital outputs.
 External Expansion Units, connected to the basic AC 20 add:
 4 analogue outputs,
 24 digital inputs,
 24 digital outputs.

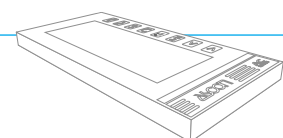
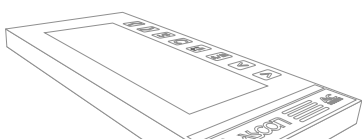
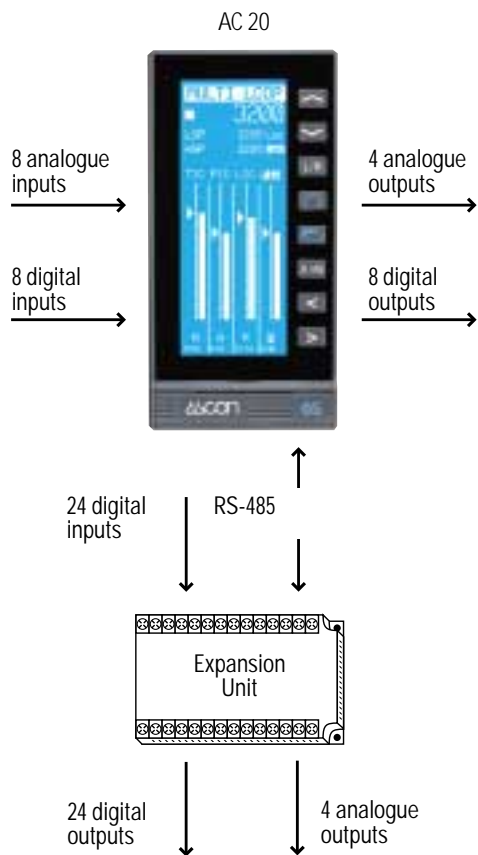

Communications

In addition to the Modbus and J-bus RS485 serial port for supervision and the RS232 programming port, the AC20 is also equipped with: a second RS485 port for the connection of the expansion units; a port for Peer-to-Peer LAN intended to build up a true mini DCS (see pages 9-10).

Programming

The required Control Strategy (CS) can be selected using the keys of the front panel, or it can be freely programmed with a PC and the AC-PROGRAPH software package running under Microsoft Windows. This software allows the programming of a CS in a simple and guided manner, picking up from a library the required function blocks (see page 5 and 6) and drawing softwirings like in a CAD program.

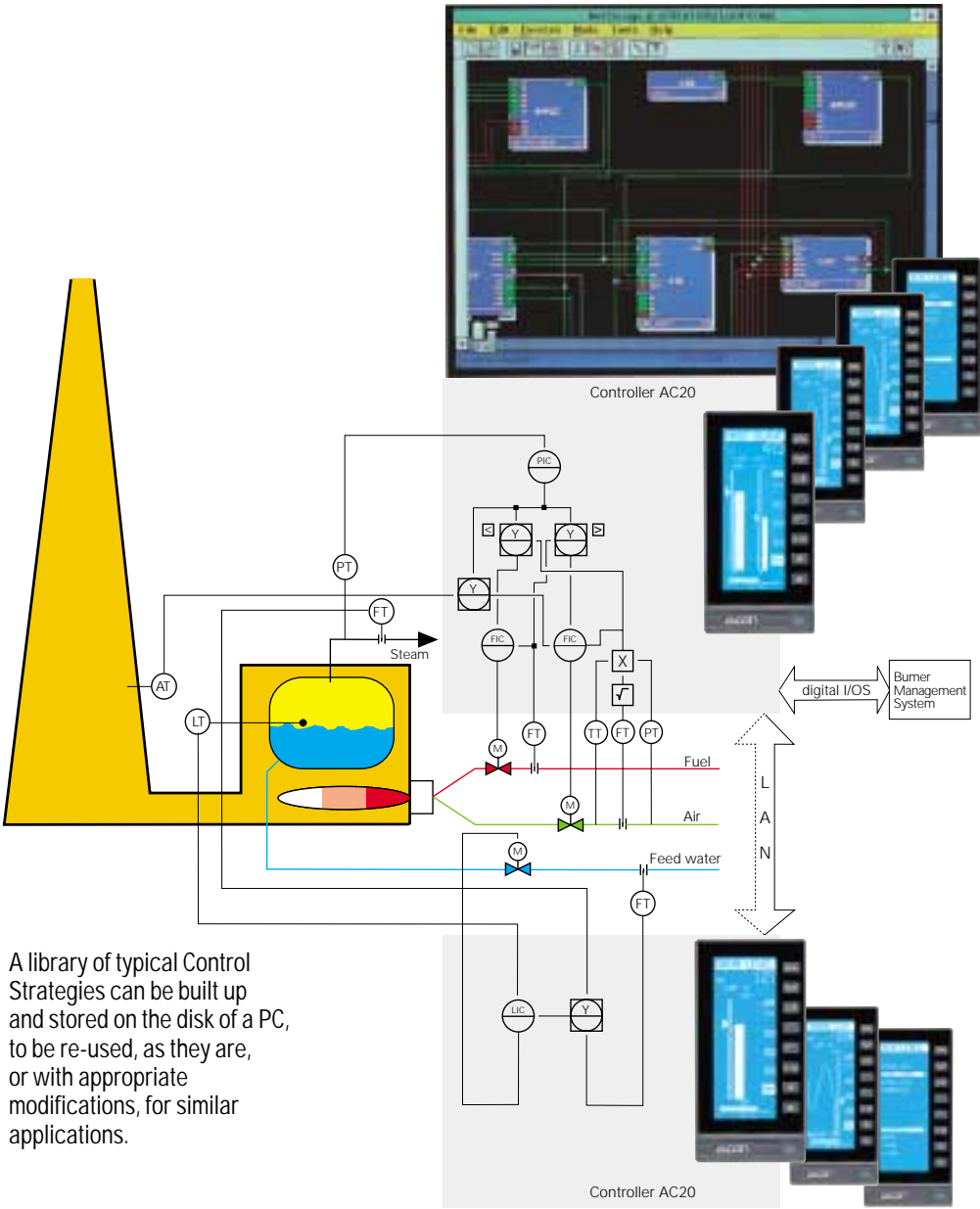

A library of typical Control Strategies can be built up and stored on the disk of a PC, to be re-used, as they are, or with appropriate modifications, for similar applications.

Complete control of a boiler with only two AC20 controllers

The first one controls the combustion with the anti-smoke system and oxygen trim. Mass flow of combustion air is computed. The second controller manages the three element control of drum level. Other applications may include double fueling and superheater control.

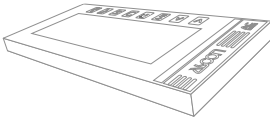

Up to 4 synchronized or independent programs / sequences

64 configurable and selectable programs / sequences

Up to 400 segments / steps totally

Powerful activity scheduler based on real time clock

Still maintaining the main hardware and software characteristics of AC 20 - I/O channels, control functions, full programmability and digital communications - AC 30 better fits the particular needs of batch process control. Setpoint profile generation and, more generally, sequence handling allow to easily manage many applications, like heat treatments, chemical reactions, environmental controls, crystal growing and material testing.

Program / sequence

Up to 4 programmers / sequencers can be simultaneously activated: each module can generate a setpoint profile with ramps and dwells and, in addition, can produce an auxiliary setpoint value and up to 16 digital commands (on - off) for each segment / step. Each programmer / sequencer provides the following commands: Start, Halt, Next Step, Fast (for a fast execution of the sequence) and Reset.

It is possible to configure automatic interlocks in case of significant deviation of process variables from ideal setpoint profiles. Programs can be repeated automatically several or infinite times. Thanks to the graphic friendly human interface normal operations and set-up functions can be accessed very easily.

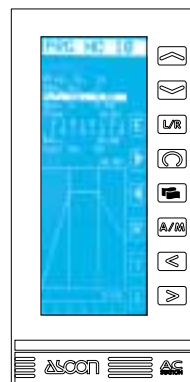
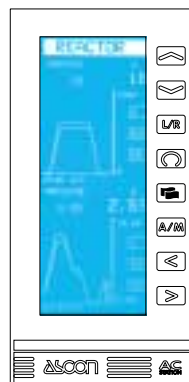
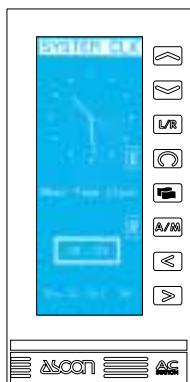

Real time clock

Batch process handling often requires automatic activation of operations on the plant or on the auxiliary equipments. To solve this problem AC 30 provides a real time clock that can be easily configured to generate up to 56 events in a week.

The clock is battery backed-up and runs also in case of main power failure: this allows the configuration of safety logics for warm and cold restart in accordance with process dynamics.

Diagnostics and safety

AC 30 is able to measure significant deviations of the controlled variables from the configured setpoint profiles and to detect short or long term power fails. As a consequence of these checks, convenient logics can be automatically activated to assure the safety of the staff and to prevent equipment or product damage; i.e.:

- warm restart
- restart from the previous step
- hold
- program / sequence reset.

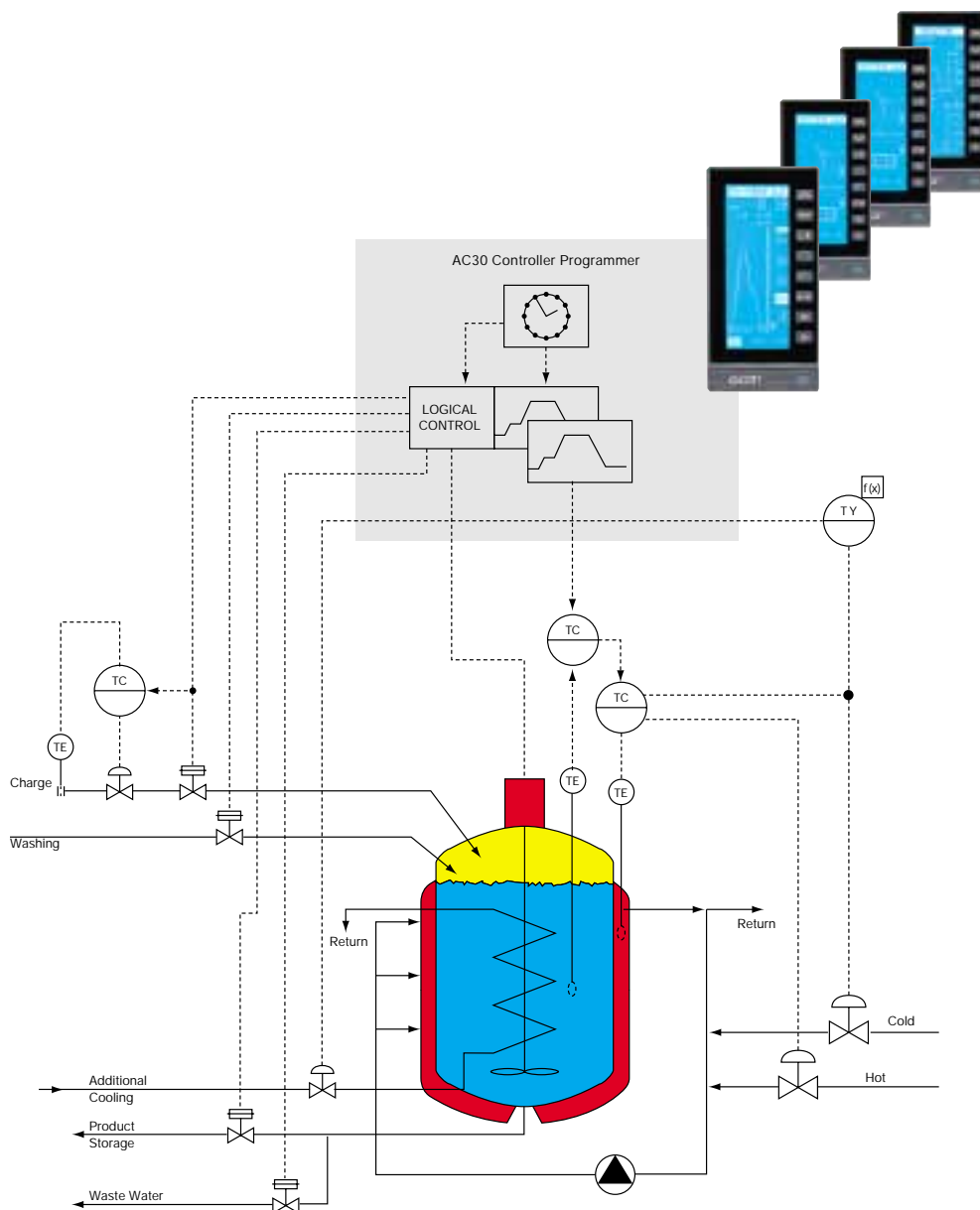

Reactor control

A single instrument can control the following phases:

- Ingredients loading, in accordance with preset quantities
- Parameter control of the reaction in accordance with preset values and times; several control strategies are available like, for example, cascade control used in processes with long lags and heat/cool algorithm required to control exothermic reactions

Furthermore several recipes for multi-product reactors can be stored and activated manually or automatically.

- Activation of commands like start/stop of stirrer, circulation pumps, ...
- Product discharge and storage
- Washing cycle

Auxiliary Units

Expansion of I/O channels

Remote I/O handling

Signal conditioning

Simplification of wiring with sensors and actuators

A complete and homogeneous series of DIN rail mounting expansion units allows to make easier field signal wirings and to increase the number of I/O channels.

Expansion Units

Each unit is equipped with a RS 485 communications line and permits to expand the number of I/O channels of AC 20 and AC 30. Connected with the expansion port of the controller, they can be mounted

at a distance of up to 1200 meters, allowing moreover to reduce cabling costs. Up to 3 Expansion Units can be connected in multidrop to each controller.

2 models are available with the following characteristics:

- **EU/88**
8 digital input + 8 digital output
- **EU/88/4**
8 digital input + 8 digital output + 4 analog output (max 1 unit).



Technical Data

AC STATION		AC10	AC20	AC30
Inputs and Outputs				
Analogue inputs	1...5Vdc/0...5 Vdc, (impedance >10M Ω) - 4...20mA/0...20mA (with external shunt) Accuracy 0,1%, resolution 16 Bit	4	8	8
Digital inputs	Passive opto-isolated. Voltage: On 8...36 Vdc, Off 0...1,5 Vdc Frequency input. Configurable range 200 Hz, 2kHz, 20kHz	8	8-32*	8-32*
Analogue outputs	Galvanically isolated from the inputs. 1...5 V dc/0...5 Vdc; 4...20mA/0...20mA (su 500 Ω) - Resolution 13 Bit	4	4-8*	4-8*
Digital outputs	Opto-isolated, solid state relay. Max load: 300 mA e 30 Vdc/Vac. Protected with auto-reset fuses	8	8-32*	8-32*
Expansion Unit	For the addition of: 4 analogue outputs, 24 digital inputs, 24 digital outputs	-	o	o
Control Functions				
Cycle time	0.1...10 sec. Adjustable	●	●	●
PID management	1...4 independent loops Advanced PID algorithm, two degrees of freedom type with Feed-Forward Gain scheduling Advanced "In Tune", natural frequency type	●	●	●
Control strategies	Resident and preprogrammed Preprogrammed and available on disk Freely programmable with PC and AC-PROGRAPH	12	12	12
Sequence	Max number of active Sequence Modules Max steps per Sequence Module Max stored Sequences per Module Analog output per Sequence Module Digital output per Sequence Module	-	-	4 100 16 2 16
Real Time Clock	Hardware with battery back-up Events on a week basis Max number of events	-	-	● ● 56
Communications				
RS 232 port	Configuration and Programming	●	●	●
RS 485 port	ModBus and J-bus protocols (slave)	●	●	●
RS 485 port	I/O Expansion Units	-	o	o
2.5 Mb/s Network	Peer-to-peer Communication	-	o	o
Physical and Environmental				
Weight	max 1700 g.	●	●	●
Front Panel Protection	IP 54	●	●	●
Supply Voltage	12 Vac 50/60 Hz	●	●	●
Power Consumption	20 VA max	●	●	●
Auxiliary Supply	24 Vdc/max 300mA for field transmitters	●	●	●
Electromagnetic Compatibility	EN 55011, EN 50081-2, EN 50082-2	●	●	●
Operating Conditions	KWF for DIN 40040	●	●	●
Operating Temperature	0...50°C	●	●	●
Storage Temperature	-20...+60°C	●	●	●
Humidity	10...90% non condensing	●	●	●

* With inner Expansion Unit ● standard o option - not available

Dimensions (compliant to the DIN 43700 standard)

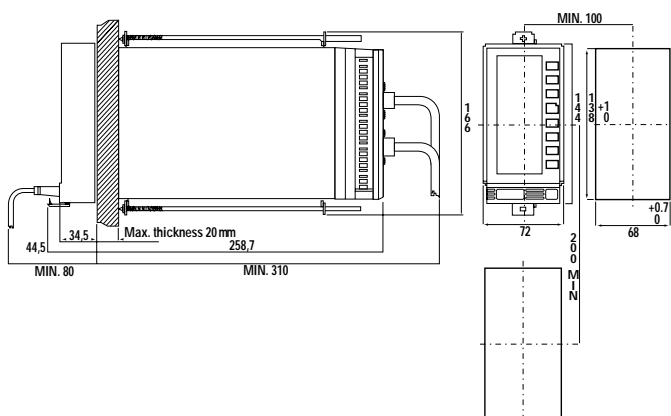

Expansion Units		EU/88	EU/88/4
Hardware			
Mechanical	DIN rail mounting	DIN 6 105 mm	DIN 9 157.5 mm
Serial port	RS 485	1	1
Voltage Supply/Consumption	11 Vac 50/60 Hz	9 VA max	11 VA max
Power Supply Transformer	220/240 Vac, 32 VA max		
Inputs and Outputs			
Digital inputs	Opto-isolated Free voltage contact	8	8
Digital outputs	Relay (220V 3A)	8	8
Analog outputs	4...20 mA	-	4

Ordering codes

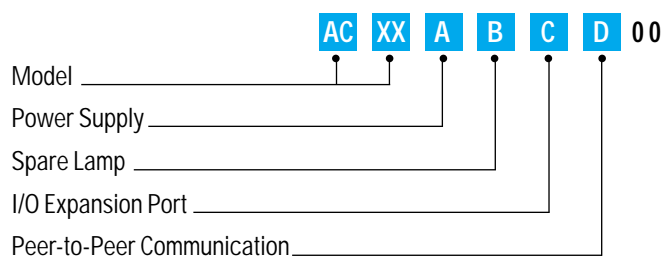

Model	XX
DIN 72x144 mm, 260 mm depth	10
DIN 72x144 mm, 260 mm depth	20
DIN 72x144 mm, 260 mm depth	30
Power Supply	A
100...240V~ 50/60 Hz	3
18...28 V, 50/60 Hz o 20...30 Vdc	5
Spare Lamp (option)	B
Not fitted	0
Fitted	1
Expansion Units Port (option) [1]	C
Not fitted	0
Fitted	1
Peer-to-peer Communication (option) [1]	D
Not fitted	0
Fitted	1

[1] = Not available for AC10

Auxiliary Units	
AAC-EU/88	Expansion Unit 8 dig/in + 8 dig/out
AAC-EU/88/4	Expansion Unit 8 dig/in + 8 dig/out + 4 an/out
AAC-TA	Power Supply for up to 3 Expansion Units

ASCON spa
 20021 Bollate
 (Milano) Italy
 Via Falzarego, 9/11
 Tel. +39 02 333 371
 Fax +39 02 350 4243
<http://www.ascon.it>
 e-mail info@ascon.it

ASCON FRANCE
 2 bis, Rue Paul Henri Spaak
 ST. THIBAUT DES VIGNES
 F-77462 LAGNY SUR
 MARNE - Cedex
 Tél. +33 (0) 1 64 30 62 62
 Fax +33 (0) 1 64 30 84 98
 e-mail
ascon.france@wanadoo.fr

AGENCE SUD-EST
 Tél. +33 (0) 4 74 27 82 81
 Fax +33 (0) 4 74 27 81 71

**WORLDWIDE NETWORK OF
 DIRECT SALES CENTRES,
 DISTRIBUTORS AND VARs**

Europe

Belgium, Cyprus, Croatia,
 Czech Rep, Finland, France,
 Germany, Great Britain, Greece,
 Holland, Ireland, Norway, Poland,
 Portugal, Romania, Russia,
 Slovenia, Spain, Sweden,
 Switzerland, Turkey, Ukrain

Americas

Argentina, Brazil, Canada, Chile,
 Colombia, Ecuador, Peru, United States

Over the world

Australia, China, Egypt, Esthonia,
 Hong Kong, India, Iran, Israel,
 Malaysia, New Zealand,
 Pakistan, Saudi Arabia, Singapore,
 Taiwan, Thailand,
 South Africa & South East Africa

Agente: