

# Multi-Input **FUZZY** Controller with serial communication 1/16 DIN - 48 x 48 mm MF line - MC line



## Intelligent

The MF and MC controllers ensure exact control under all conditions, thanks to the PID-FUZZY algorithm action.

## Simple

PID-FUZZY parameters are suitable for most processes; they can, however, be easily optimized by the launching of automatic tuning.

## Unique

With PID-FUZZY control. With universal input for thermocouples, Pt100, mA or Volt, totally configurable from keyboard. With serial communication.

**MF Series** with discontinuous outputs with relay and logic voltage 0/18 Vdc.

**MC Series** with continuous outputs 4...20 mA and discontinuous logic voltage 0/18 Vdc.



Certified ISO 9001

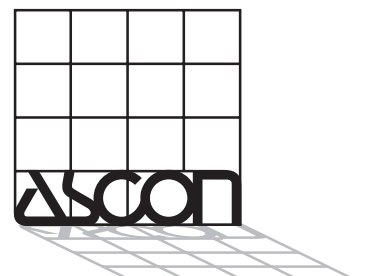

**ASCON spa**

20021 Bollate - (Milano) Italy - Via Falzarego, 9/11 - Tel. +39 02 333 371 - Fax +39 02 350 4243  
http://www.ascon.it e-mail info@ascon.it

# MF Series controller

The intelligence of the **FUZZY** algorithm by ASCON at the service of both process and operator...

ASCON has set-up for this instrument an innovative control technique based on **FUZZY** logic combined with the standard PID.

## What is **FUZZY**

The "**FUZZY**" logic, which means "Shaded" logic uses some concepts of the artificial intelligence, based upon a block of rules permitting action not by the evaluation of binary states (for instance: black/white, open/closed, heat/cool) but by the evaluation of intermediate states (for instance: hot, warm, tepid, cool, cold). This operating mode is similar to human reasoning, with shades leading to better evaluations and therefore stronger corrective actions.

## WHY **FUZZY**

The PID-**FUZZY** control by ASCON offers, in practice, the following advantages:

It reacts quickly and without unwanted oscillations to load and Set point changes.

It allows a good control of difficult processes, especially in the presence of changes to the operating conditions.

The standard **FUZZY** parameters are factory set and are applicable for the most processes; however, if necessary, they can be easily tuned through launching of the automatic optimizing procedure. Therefore, the ideal controller for all the operators.

Comparison of step response curves between PID algorithm and ASCON **FUZZY** algorithm in different operating conditions.

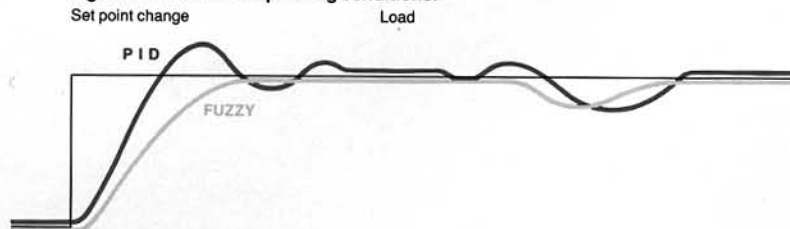

Note: the PID parameters have been optimized before the change

**Universal power supply**  
From 100 to 240 Vac.

**Auxiliary power supply**  
For external transmitter

**Complete display**  
For a clear indication of process value, Set point, outputs, configuration and parameters.

**Total configurability from keyboard and serial interface**  
For: input, scale range, type, operation and safety state for main and auxiliary outputs.

**Main output**  
(MF Series) discontinuous with relay and logic.  
(MC Series) continuous 4...20 mA and logic.

**Serial communication**  
For access to all controller parameters and integration into a distributed control network.

**Maximum protection**  
High interference immunity, access to parameters via password.  
IP54 or IP65 front protection.

**Soft and exact control.**  
Thanks to the combination of PID and FUZZY algorithms.



... in the most complete and simple to operate of the small controllers

# Technical data

## UNIVERSAL INPUT

The following functions are configurable from the keyboard:

- type of input signal
- scale range with zero and full scale values (for mA or Volts signals)
- selectable °C/°F.
- For thermocouples (J,L,K,S,R), for Pt100 and for signals in mA and Volt.
- Accuracy: 0.1...0.2% at 25°C
- Sampling time: 0.5 sec.
- Line resistance: 150Ω max for thermocouples 20Ω max for Pt100, 3-wire connection
- Input resistance: 20Ω max for 4...20 mA 10kΩ min. for 0...10Volt
- Input shift: -50...50 digits.

## MAIN OUTPUT Y1

Can be with direct or reverse operation; the upper limit is adjustable from 10 to 100%.

Are present the following 2 types:

- **MF Series**
  - With relay: 1 NO contact, 3A/250 Vac max
  - Logic voltage: 0/18 Vdc ± 10%, 25mA max, suitable for driving relays and static contactors
- **MC Series**
  - Current: 4...20mA, 450Ω max, 10 Volt max
  - Logic voltage: 0/18 Vdc ± 10%, 25mA max, suitable for driving relays and static contactors
- **Common for both series**
  - Dual action (see fig.1 for example Heat-Cool) Y2 output (with relay or logic output) is used for cool control.

## AUXILIARY OUTPUT Y2

The following functions are configurable from the keyboard:

- The control mode: active High or active Low (i.e. is relay energised above or below the threshold)
- The type of set point:
  - Band: from 0 to 300 units (with or without startup inhibition)
  - Independent: within the scale span
  - Deviation: from -300 to + 300 digits
- Loop break Alarm: to signal failure or interruption of the control loop, shown by display flashing.
- Output: 1 NO contact 3A/250 Vac max. (Logic 0/18 Vdc on request)
- Hysteresis: 0.1 to 10.0%
- Upper limit: from 10 to 100%.

## CONTROL

The main control algorithm features On-Off, PID-FUZZY, PID (I and D actions can be excluded).

### Parameters:

- Proportional band: from 0.5 to 500%
- Integral time: from 0.0 to 100 minutes

- Derivative time: from 0.0 to 10 minutes
- **FUZZY** intensity: from 0 to 90%

### For time-proportional controls:

- Cycle time: from 0 to 200 sec.

### For On-Off controls with hysteresis:

- Hysteresis: from 0.1 to 10.0%

### For dual-action controls:

- Cycle time and maximum output value can be separately set for the 2 channels.
- Dead zone between the two control actions: 0,0 to 5% of Y1 (see fig. 1).

## SET POINT

It is possible to set:

- the upper and lower limit within the scale range
- the up and down gradient from 0.1 to 100 digit/min.

## POWER SUPPLY FOR TRANSMITTER

- to supply a 2-wire 4...20 mA transmitter or a 3-wire 24 Vdc transmitter.

## SERIAL COMMUNICATION

- Passive isolated interface
- 2-wire connection: line continuity is guaranteed also in the event of withdrawal of one or more instruments.
- Protocol:
  - ASCON through ASCII codes
  - configurable ModBus/JBus RTU formality
- Baud rate configurable between 600, 1200, 2400, 4800, 9600 Bit/s
- Interface with RS232, RS422A, RS485 port via traffic concentrator type ALS (it's possible to connect up to 64 ASCON instruments also of different type).

## PROTECTIONS

- Input: overrange or a failure on the input line (break or short circuit) is displayed and forces the outputs to the value of the safety state selected within the configuration.
- Safety state: main output Y1: 0 or 100% auxiliary output Y2: 0 or 100%
- Parameters: accessible via password.

## GENERAL CHARACTERISTICS

- Power supply: 100...240V, 50/60 Hz, -15 + 10% (250 V max) or 16...28V, 50/60 Hz and 20...30 Vdc
- Power consumption: 4 VA max
- Isolation group: C to VDE 0110
- Climatic category: KWF to DIN 40040
- Ambient operating temperature: 0 to 50°C
- EMI suppression: level IV according to IEC 801-4 for heavy conditions
- Protection mode to DIN 40050 front panel: IP54 housing: IP30 Terminals: IP20 Housing material: UL 94V1

- Weight: approx 0.2 kg
- Dimensions: 48x48 dept 110 mm. (behind panel)

Fig. 1 Auxiliary control output Y2

### Dual action (Heat-Cool)

With Y1 configured for reverse operation and Y2 configured for Heat-Cool operation

Yh : limits Y1 between 10 and 100%  
Yh2: limits Y2 between 10 and 100%  
db: dead zone between 0.0 and 5.0%

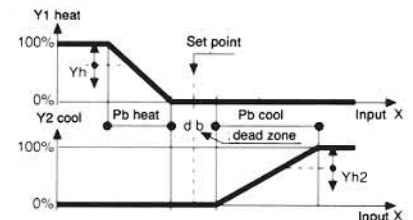

With  $r c r$  = relative gain of cool action from 0.1 to 3.0

$$Pb \text{ cool} = \frac{Pb \text{ heat}}{r c r}$$

### Band with inhibition

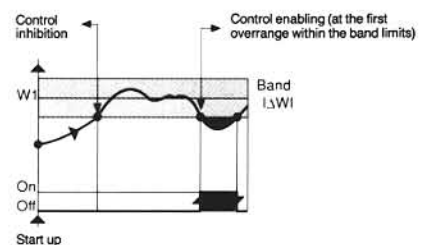

### Band (IΔW1)

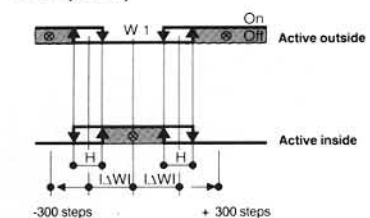

### Independent set point W

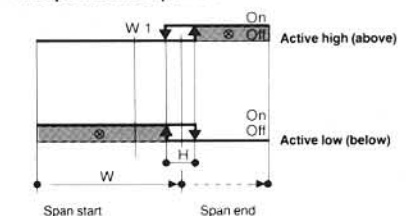

### Deviation set point ΔW

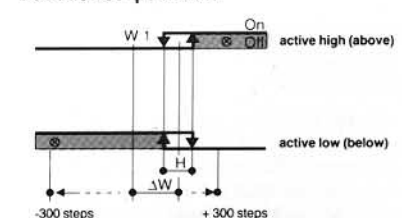

The setting range of Set point limits for Y2 is not limited by the limit of the main Set point W1 but only by the scale span.

# Models and configurations

DISCONTINUOUS OUT-PUT MF - **A B** / **C D E F** / **G** ... **H**

CONTINUOUS OUT-PUT MC - **A B** / **C D E F** / **G** ... **H**

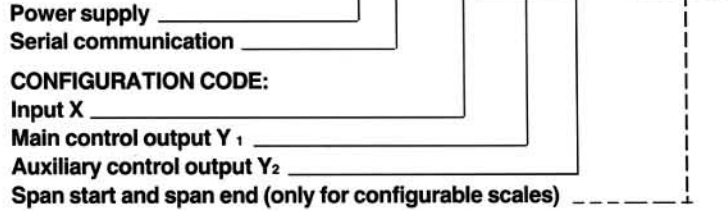

## MODEL CODE:

Power supply	A
100...240 V 50/60 Hz	3
18...28 V 50/60 Hz and 20...30 Vdc	5

Serial communication	B
None	0
Ascon Protocol	1
Modbus/JBus Protocol	2

## CONFIGURATION CODE: (1)

Input type and scale range (2)		C
Thermoresistance IEC 751	Pt100 -200...600°C	0
	Pt100 -300...1100°F	0
	Pt100 -99,9...300,0°C	1
	Pt100 -99,9...500,0°F	1
Thermocouple IEC 584	Type J 0...600°C	2
	Type J 32...1032°F	2
	Type L 0...600°C	3
	Type L 32...1032°F	3
	Type K 0...1200°C	4
	Type K 32...2032°F	4
	Type S 0...1600°C	5
	Type S 32...2832°F	5
4...20 mA	Conf. eng. units	6
0...20 mA	Conf. eng. units	7
0...1 Vdc	Conf. eng. units	8
0...10 Vdc	Conf. eng. units	9

Type of output Y <sub>1</sub>	D
Relay 3A/250 Vac (MF Series)	0
Continuous 4...20 mA (MC Series)	0
Logic 0/18 Vdc	1

Type of operation and safety state Y <sub>1</sub>				E
On-Off	Reverse	Safety	0%	0
	Direct	Safety	0%	1
PID-FUZZY	Reverse	Safety	100%	2
	Direct	Safety	100%	3
On-Off	Reverse	Safety	0%	4
	Direct	Safety	0%	5
PID-FUZZY	Reverse	Safety	100%	6
	Direct	Safety	100%	7
On-Off	Reverse	Safety	-100% (3)	8
	Direct	Safety	-100% (3)	9

(\*) Only for relay and logic outputs

Type of Set point and control mode output Y <sub>2</sub>		F
Disabled		0
Heat- Cool		1
Band with inhibited Start up	Active outside	2
	Active inside	3
Band	Active high	5
	Active low	6
Independent	Active high	7
	Active low	8
Deviation		9
Loop Break Alarm		9

## Notes on configuration:

- To receive a non - configured instrument, indicate code 9999
- For mA and Volts inputs, span start and span end values can be configured in engineering units between -999 and 9999. The minimum scale span is 100 steps. The values can be expressed in units (xxxx), in tenths (xxx.x), hundredths (xx.xx), or thousandths (x.xxx). In the absence of indications, the instrument will be supplied with 0.0...100.0 scale.

3 - For Heat-Cool action (F = 1)

## Ordering examples:

**MF-30/4107**

Defined configuration

**MF-31/6109/50.0...150.0**

Configuration with scale range in engineering units

**MC-31/9999**

Not configured

## ACCESSORIES

- SERIAL COMMUNICATION INTERFACE** for 64 ASCON instruments

Model: ALS -  /

### Power supply

100...240V, 50/60 Hz

16...28V, 50/60 Hz

### Interface

RS232

RS422

RS485

232
422
485

## Front or rear panel mounting

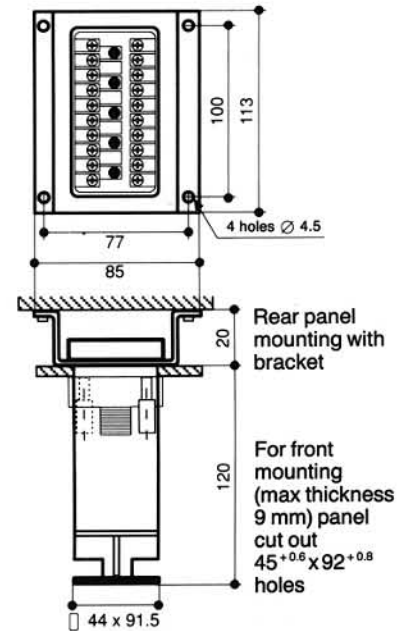

- FRONT PROTECTION KIT IP65: mod. F10-141-1A1MS**

