

Process Controller 1/4 DIN - 96 x 96 mm Dual-loop - QD line Controller - Programmer QP line

The Hardware Package

2 analog inputs, 1 remote set input, 3 logic inputs, 2 control outputs, 4 auxiliary relay outputs, 2 logical outputs, 1 retransmission and RS485 Modbus-Jbus communication.

Complete Configurability

From the keyboard and via serial connection, using a guided menu, you can choose the operation mode, the control algorithm, the input and output types, the Set points. You can also insert all parameters.

FUZZY Intelligence

In combination with the PID algorithm and an advanced tuner, this always guarantees a smooth and precise regulation, even for critical processes.

High Security

Guaranteed: by the ISO9000 certificate for planning and construction quality; by the CE brand for security and immunity from disturbances; and by 3 levels of accessibility to parameters.

These 96x96 DIN controller-programmers are particularly suitable for the control of industrial processes.



E

Certified ISO 9001

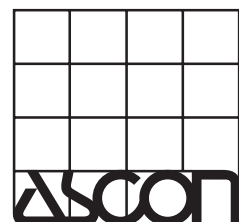

ASCON spa

20021 Bollate - (Milano) Italy - Via Falzarego, 9/11 - Tel. +39 02 333 371 - Fax +39 02 350 4243
http://www.ascon.it e-mail info@ascon.it

**QD Series - Dual Controller configurable as:
1 loop, cascade, ratio or 2 independent loops**

**QP Series - Controller-Programmer
16 programs 255 segments**

All the performance for precise and safe control

The Hardware Package

- Up to 2 inputs for thermocouples, Pt 100, mA, Volt.
- 3 logical inputs for modifying the operating modes: Auto/Man, Local/Remote, keyboard lock, etc...
- Up to 2 control outputs with single or double action: relay or logic, mA or Volt and three point stepping.
- Up to 4 configurable auxiliary relay outputs and 2 logic outputs associated to the program.
- 1 isolated auxiliary output, in mA or Volt, for input, Set point, output or deviation retransmission.
- All types of Set points. The possibility of selecting between Local and Remote, Programmed (QP Series), and of choosing one among the 3 stored Set points.
- RS485 serial communication, with Modbus-Jbus protocol.

Complete Configurability.

The possible variants are all always available in the instrument. The operation mode is chosen based on the application. In field operation it is always possible, with the greatest simplicity, to reconfigure the instrument to adapt it to unexpected new requirements. The configuration is effected by keyboard or in serial line. Using a simple, menu-driven tree structure, you can choose, in sequence: control algorithm, input types, ranges, engineering units, output type with security values, Set points, etc...

Fuzzy Intelligence and an advanced "Tuning"

The power and flexibility offered by an advanced PID combined with FUZZY Logic guarantee a precise regulation of the most critical processes, whether in response to the dynamic solicitations or to any variations of the Set point. The tuning of the control parameters is highly facilitated by the use of an intelligent self-tuning algorithm.

Maximum Protection

All parameters are saved for an unlimited time in non-volatile memory. Their access is protected by password. They are divided into 4 homogeneous groups and are configurable with 3 different levels of operativity: visible and modifiable, visible but not modifiable, invisible. All this gives the instrument more security, but at the same time, more ease for the final operator, without limiting the great flexibility of use.

High Security

Like all ASCON instruments, these are designed in conformance with the most recent EN-IEC security regulations for industrial systems and apparatus, marked with the CE brand, and built in accordance with ISO9002/EN29002 Quality Assurance Management System, guaranteed by CSQ.

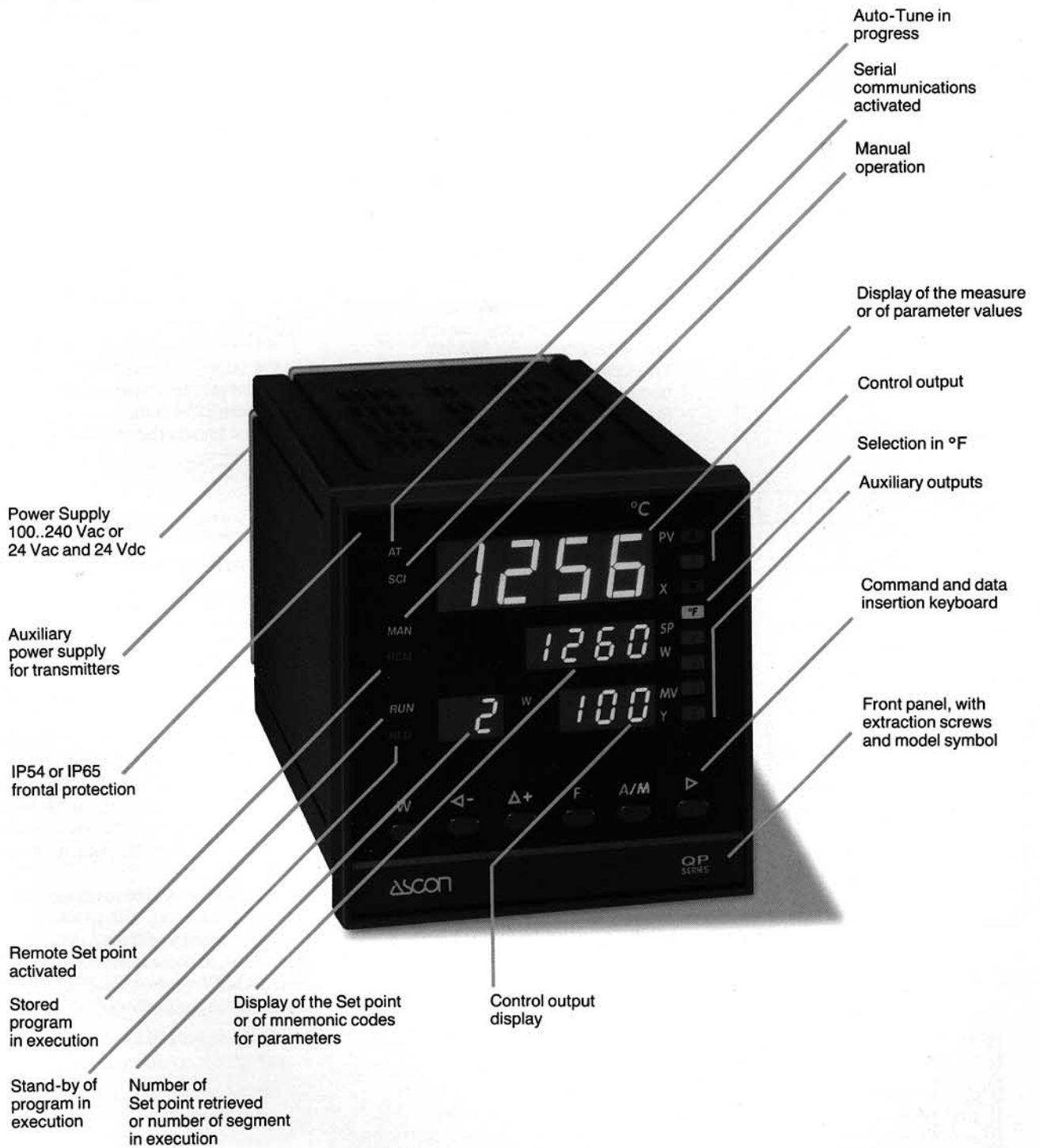

Operation

Fig. 1: Block diagram of Cascade control mode

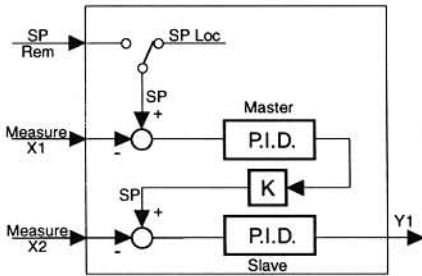

Fig. 2: Block diagram of Ratio control mode

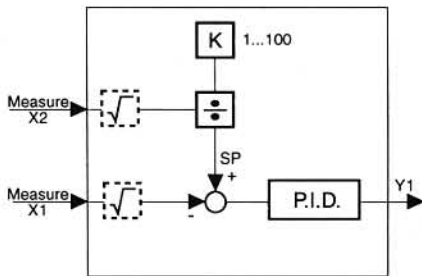

Fig. 3: Outline of Programs selection switch

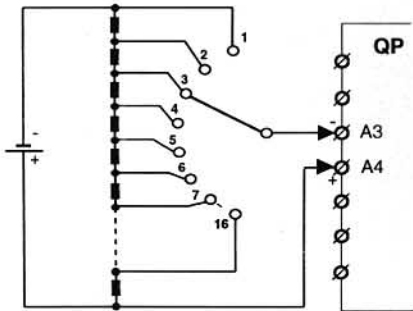
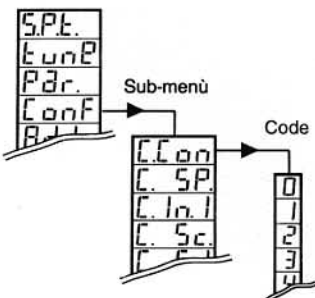

Fig. 4: Tree-structure of Function Menu



OPERATIONAL MODES

The QD Series process controller includes 2 distinct loops which can be coordinated with each other.

4 selectable operational modes are planned, in configuration as:

- 1 loop with single or double action,
- Cascade control loop with single or double action,
- Ratio control loop with single or double action,
- 2 independent loops.

Cascade Control (See fig. 1)

The primary controller output (Master) becomes the Set point for the secondary controller (Slave). This operational mode is particularly useful in critical processes, where there are long delays, dead times, non linearity, etc.

In fact, the secondary controller anticipates and practically cancels the perturbances acting on the primary process for a more efficient and stable control.

Ratio Control (see fig. 2).

A ratio between two variables in the process is maintained at a fixed value. Thanks to the capability of calculating the square root of the input values, it is suitable for combustion control (air/fuel ratio) or for the mixing of 2 fluids.

Set point Programmer

QP Series are single loop controllers, offering programmed Set point as an additional option. When operating as Controller-Programmer, a program is built using a simple guided procedure, formed out of the sequence of segments (see fig. 5).

For each of these segments, the end point is set along with the time, in addition to the associated logic output status and to the PID parameters chosen between two available sets. The number of loops (finite or infinite) is configurable, as is the execution mode: based on duration priority or on slope-priority of the segments. Up to 16 programs can be stored, with a max of 99 segments/program, for a max of up to 255 segments.

You can select, run and suspend the program from the keyboard, from logic inputs or through serial port. A program can also be executed easily using and external voltage divider (see fig. 3).

Display of the progress status (segment being executed, time elapsed, time left, etc.) helps the operator.

MENU DRIVEN FUNCTIONS

The man-machine interface is made simple by menus.

The tree-structured main menu passes to the submenu and then to the insertion of parameters and configuration codes.

Figure 4 shows the menu structure.

CONTROL ALGORITHM

The QD and QP Series controllers use an innovative control technique based on **FUZZY** logic, combined with the traditional PID.

"FUZZY" logic uses some concepts from artificial intelligence.

At the basis is a set of rules allowing it to act not on the basis of binary statuses (for example, black/white, open/closed, hot/cold), but rather on the evaluation of intermediary statuses (for example, very hot, hot, lukewarm, cold, very cold).

This operation mode is similar to human reasoning, with gradations leading to more real evaluations, and therefore, to more corrective actions. PID-FUZZY control, by ASCON, offers the following substantial advantages:

- reacts rapidly to load and Set point variations, avoiding overshooting;
- allows accurate control of critical processes, even when there are significant changes in the operational conditions (see fig. 6).

The controller calculates the "FUZZY" parameters automatically, deriving them from PID parameters optimized at the time of launching.

Fig. 5: Example of Programmed Set point with priority slope.

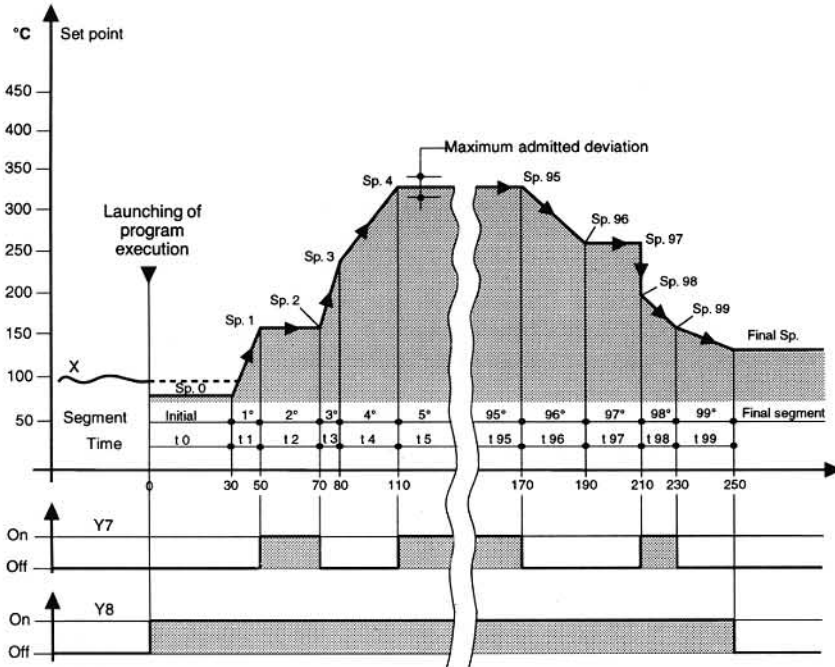

- Notes:**
 1 With duration of initial segment $t_0 = 0$, execution begins from segment 1 with $W = X$
 2 With deviation greater than a maximum admitted value, time count stops in order to guarantee scheduled duration.

Fig. 6: Comparison of step response curves between P.I.D. algorithm and P.I.D.+Fuzzy algorithm in different operating conditions.

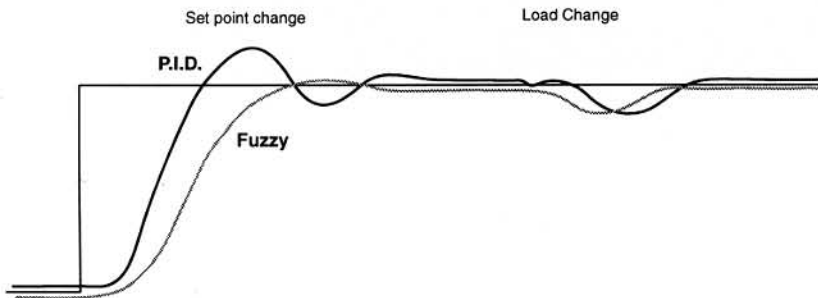

Note: P.I.D. parameters have been optimized before the change

Fig. 7: " Natural Frequency " tuning (In Tune)

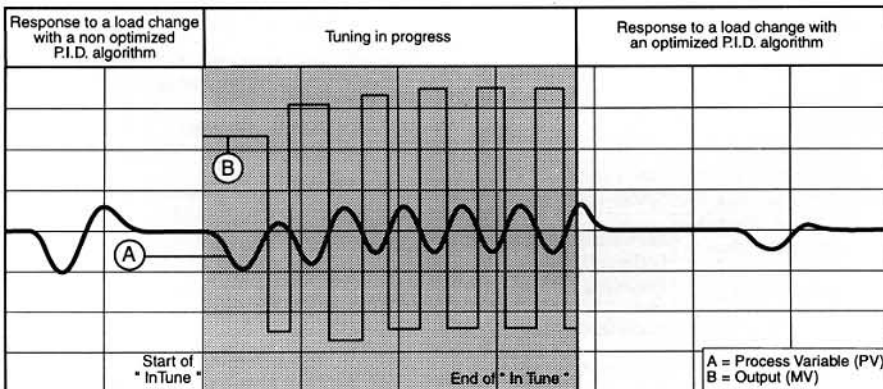

Self-tuning "In-Tune"

This is a new method for calculating the PID parameters, called that of "natural frequency". Tuning can occur at a Set point change or during process steady conditions. The method consists in the analysis of the response of the process of solicitations, even very small ones, imposed by the controller for calculating the natural frequency of the process. The result is a great deal better than that obtainable using conventional methods, such as Ziegler and Nichols or similar ones (see fig. 7).

Technical data

Features at env. 25°C	Description			
Total Configurability	From the keyboard or serial line, with a guided menu, you can choose, in sequence: type of control, operational mode, inputs, outputs, Set points and insert all control parameters.			
Operational Modes	1 Loop with single/double output			
	1 Loop as above and programmed Set point	Only for QP Series		
	2 independent loops	Only for QD Series		
	Cascade (1 master + 1 slave)			
Ratio (direct/reverse)				
Control	Algorithm	On-Off, P.I.D., PID + FUZZY and PID with "three point stepping" output		
	Supplementary P.I.D. parameters for main loop			
	Prop. Band (P)	0.5...999.9%		
	Integral T. (I)	0.1...100 min		
	Derivative T. (D)	0.01...10 min	Excludable with 0.0	
	Fuzzy Intensity	0.0...90%		
	Output Man.Reset	0...100%		For P and PD control
	Cycle T.	1...200 sec.		"Duty Cycle" output
	Hysteresis	0.01...10%		For On-Off control
	Dead Band	0.0...5%		Heat/Cool output
	Relative cool gain	0.1...3		
	Excursion T.	15...600 sec		Three point stepping output
	Min output resol.	0.1...10%		
Potentiometer	100Ω...10KΩ			
Input X1 (range, see tab. 1)	Common characteristics			
	A/D converter with 50.000 points Sampling time: 0.5 to 30 sec., configurable Input shift: -60... + 60 digits Input filter: 0...30 sec			
	Accuracy	0.2% ± 1 digit (T/C, RTD) 0.1% ± 1 digit (mA, V)		
	Resistance Thermometer	Pt100Ω at 0°C (IEC 751) With selection °C / °F / °K	Connection with 2 or 3 wires	Between 100...240Vac, error is irrelevant Line: 20Ω max (3 wires) Thermal drift: < 0.1°C/10°C env. T. < 0.5°C/10Ω line R.
	Thermocouples	L, J, T, K, R, S, B, N, E, W (IEC 854) with selection °C / °F / °K	Cold joint compensation, internal or external in °C / °F / °K	Line: 150Ω max Thermal drift: < 2µV/°C env. T. < 5µV/10Ω line R.
	Continuous current	4...20mA, 0-20mA Ri = 30Ω	Engineering units, floating point, with or without sq.rt.	Input drift: < 0.1%/20°C env. T.
Continuous Voltage	0-20mV, 0-50mV Ri = 10MΩ 0-1/1-5/0-5/0-10V Ri = 10kΩ	L.R. -999..9999 H.R. -999..9999 (min 100 digits)		
Input X2	Characteristics identical to input X1 (only for QD Series)			
Auxiliary Inputs	3 logic	Permanent closure of external associated allow:	Auto/Man switching, Local/Remote Set point selection, recall of 3 stored Set points, keyboard lock, 2nd PID parameters set, Y1 = Remote Set point, Y1 = forcing value	
			Run, hold, wait...program (only for QP Series)	
Main output Y1	Single of dual, with direct or reverse action (for combinations of possible outputs, see below)			
	Lower limit	0...90% (Heat)		
	Upper limit	100...10% (Heat), -100...-10% (Cool)		
	Max slope	0...20%/sec. (Heat / Cool)		
	Safety value	0...100%, -100...100% (Heat / Cool)		
	Forcing value	0...100%, -100...100% (Heat / Cool), from logic input		
	Discontinuous	Discontinuous Relay, 2 NO contacts, 5A/250Vac, 2x10 ⁵ transitions		
		Logic	0-22Vdc, 20mA (for solid state relay)	
	Continuous	Current	0-20mA, 4-20mA 750Ω/10V max	
		Voltage	1-5V, 0-5V, 0-10V 500Ω/20mA max	
"Three Point Stepping"			Dual action relay, 2 NO contacts, 5A/250Vac, 2x10 ⁵ transitions	

Table 1: Input X1

Input type, scale range	
Pt100Ω at 0°C Thermoresistance	-200...600 °C -328...1112 °F
	-99.9...300.0 °C -99.9...572.0 °F
J Thermocouple Fe-Cu 45% Ni	0...600 °C 32...1112 °F
L Thermocouple Fe-Cu/Ni	0...600 °C 32...1112 °F
T Thermocouple Cu - CuNi	-200...400 °C -328...752 °F
K Thermocouple Cromed Alumel	0...1200 °C 32...2192 °F
S Thermocouple Pt10% Rh-Pt	0...1600 °C 32...2912 °F
R Thermocouple Pt13% Rh-Pt	0...1600 °C 32...2912 °F
B Thermocouple Pt30% Rh-Pt6%Rh	400...1800 °C 752...3272 °F
N Thermocouple Nicrosil-Nisil	0...1200 °C 32...2192 °F
Thermocouple Ni-NiMo18%	0...1100 °C 32...2012 °F
W Thermocouple W3%Re-W25%Re	0...2000 °C 32...3632 °F
4...20mA, 0..20mA	Configurable eng. units *
0..50mV, 0..200mV 0..1V, 1..5V, 0..5V 0...10V	

* Linear or with square root extraction and decimal point selection

Dual action

For processes with "dual action" output Y1 (for example Heat-cool), two outputs are available with the following possible combinations:

Y1 Heat	R	L	R	C	R	C	L	C
Y1 Cool	R	R	L	R	C	C	C	L

R =Relay; L =Logic;
C =Continuous (mA or Volt);

When Y6 continuous output is used for Y1 cool, the retransmission output is not available.
4...20 mA or 0...10 Vdc.

Features at env. 25°C	Description			
Auxiliary outputs Y2-Y3 (also available for loop 2 in QD Series)	Relay with NO contacts, 5A/250Vac, 2x10 ⁵ transitions - Hysteresis 0.01...10.00%			
	Action Mode	High Active	Type of action	
		Low Active		
		Special Functions		Sensor break
		Security status		Security enabled or disabled with NO or NC contact
	Deviation Set point	± 300 digits		
	Band Set point	0...300 digit		
	Indep. Set point	from HR to LR		
	Set point to Y1	0...100%		
Auxiliary outputs, Y4-Y5	Same characteristics of Y2-Y3 (available only if continuous Y1)			
Auxiliary analog output Y6 (option)	Galvanic. isolated: 500 Vac/1 min Protected from s.c. 12 bit (0.025%) Accuracy: 0.1%	Current: 0-20mA, 4-20mA 750Ω/10V max Voltage: 1-5V, 0-5V, 0-10V 500Ω/20mA max	Input retransmission X1 Set point retransmission W1 Output retransmission Y1 (1st channel Δ) Output retransmission Y1 (2nd channel ∇) Error retransmission (0 to 25% of the range)	
	2 logic outputs (QP Series only)		Open collector, 500 Vac isolation Vac max/1 min. 30 mA max, 28 Vdc (OFF status) Voltage drop: 1Vdc max - 30 mA	
Set point	Up or down ramp can be set in digits/min, between 0.0...10% of the range		Local Local and 3 stored Remote only Local and remote Local and (local + remote) Programmable (only for QP Series)	
	Limits: lower to upper can be set separately within the range			
	Remote Set point (not available with programmed Set point option)	Not isolated Accuracy 0.1%	Current: 0-20mA, 4-20mA Ri = 30Ω	Bias in engineering units -100% + 200% (compatible with display)
			Voltage: 1-5V, 0-5V, 0-10V Ri = 300 kΩ	Ratio: -9.99... + 10.00 Local Set point + Remote Set point
			16 programs max, 99 segments /program max, 255 segments total. From 1 to 9999 repetitions / program or infinite. Time base configurable in seconds, minutes, hours. Priority of duration or slope. Up to 6 logic outputs and 3 logic inputs, programmable and related to the program. Selection between the 2 available sets of PID parameters for each segment. Auxiliary voltage input for selecting the program remotely. Run, hold, wait, etc., executable from the keyboard, logic inputs and via serial port.	
Auto-tune	With "Natural Frequency" method. Tuning can occur at a Set point change or during process steady conditions, with launch enabling index.			
Auto-Man st.	Incorporated, with Bumpless action Switching from keyboard, logic inputs, or via serial port			
Serial Comms. (option)	RS 485, Modbus, Jbus protocol, 1200, 2400, 4800, 9600 bit/sec., 2 wires, (read only or read/write)			
Auxiliary power supply	24 Vdc ± 10%, 50 mA max Up to 2 external transmitters (2, 3, 4 wire connections)			
Operational security	Main input	Out of range or hardware failure (short or open circuit) is monitored and the outputs are forced to security values		
	Control output	Settable security value: 0...100%, -100... + 100% (for double action)		
	Auxiliary outputs	Security status can be configured: excluded, NO or NC		
	Parameters	All parameter values are saved for unlimited time in non volatile memory. Subdivided into 4 homogeneous groups, configurable as: visible and modifiable, visible or not modifiable, invisible		
General features	Access keys	"Password" for accessing the V ^o group of parameters, to programming parameters for the Set point and for the configuration.		
	Power supply	100...240V, 50/60 Hz, -15.. + 10% (250Vac max) or 16...28V, 50/60 Hz and 20...30Vdc Consumption: 5VA max		
	Isolation according to ENS 1010	Double isolation power, pollution level 1, installation category II ^o		
	Electromagnetic compatibility	According to norms required for CE brand for systems and industrial apparatus		
	Environmental	KWF according to DIN 40040, operating temperature 0...50°C		
	Protections according to DIN 40050	IP 54 (front panel), IP30 (guard), IP20 (terminal block) material guard UL 94 V1		
	Mechanical 96 x 96 DIN, depth 150 mm, weight 0.8 kg appr.			

Fig. 8: Output characteristic for dual action controllers. Example: Heat - Cool

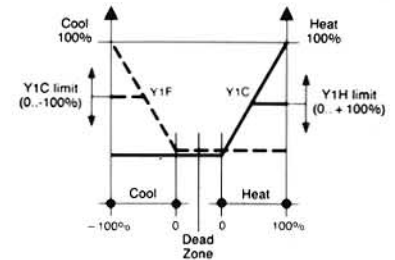

Y1C = Cool output (---)
Y1H = Heat output (—)
Indication for Y1: -100%... + 100%

Fig. 9: Auxiliary control outputs Y2 and Y3

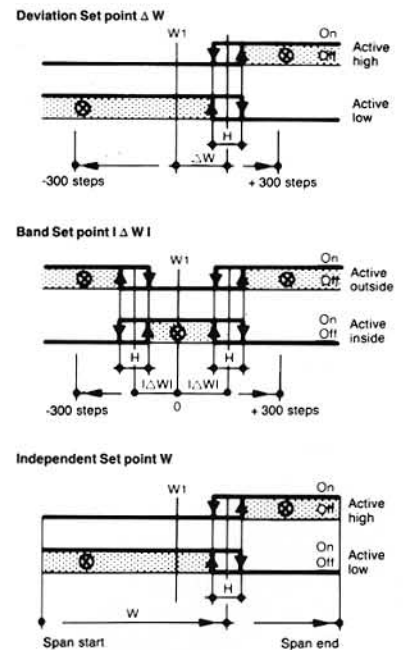

Note:
W1: Main Set point
H: Auxiliary outputs hysteresis

Fig. 10: Example of Bias and Ratio setting for a Controller with scale range 0...500 bar

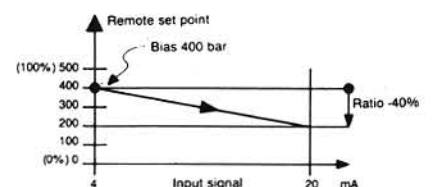

Connections and fitting dimensions

CONNECTIONS

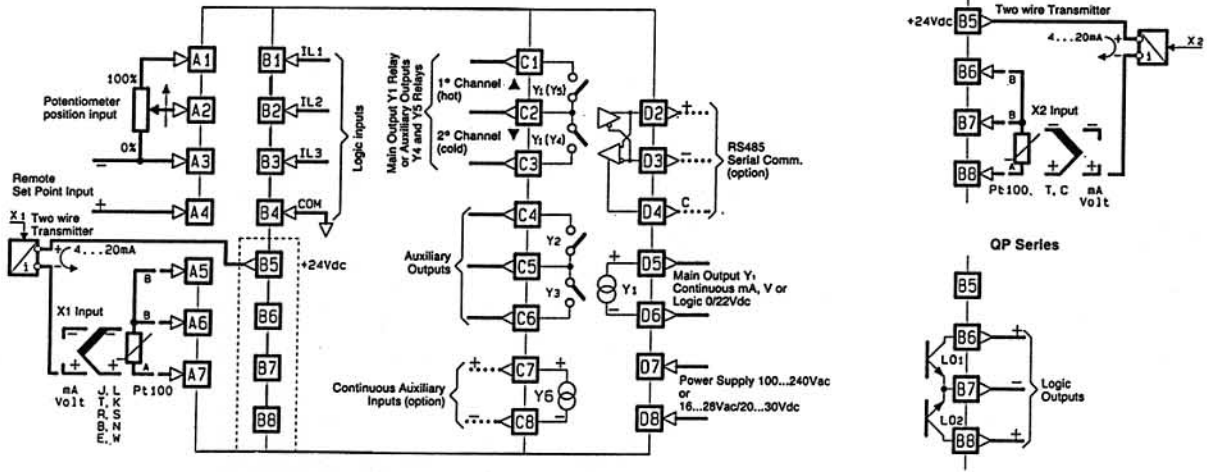

- Notes:**
- To supply a 3 or 4 wire transmitter, use terminals B5 (+) and A6 (-) or B5 (+) and B7 (-)
 - Main control output Y1 can be selected within the 5 built-in possible functions: relay (terminals C1 and C2), logic or continuous 4...20 mA or 0...10 Volt (terminals D5 and D6) and three point stepping (terminals C1, C2 and C3).

OVERALL DIMENSIONS

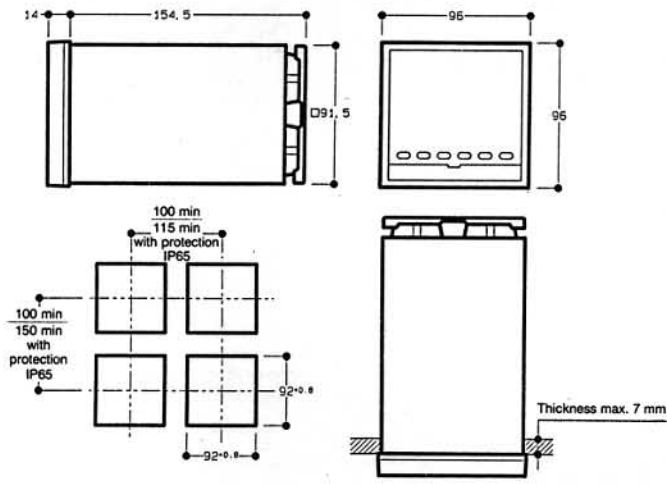

FRONT PROTECTION KIT IP65: mod. F10-435-2A101

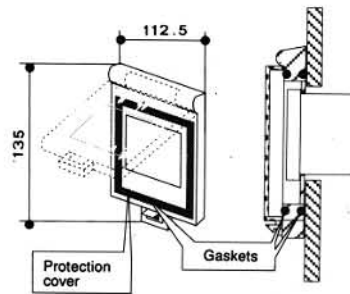

Ordering Codes

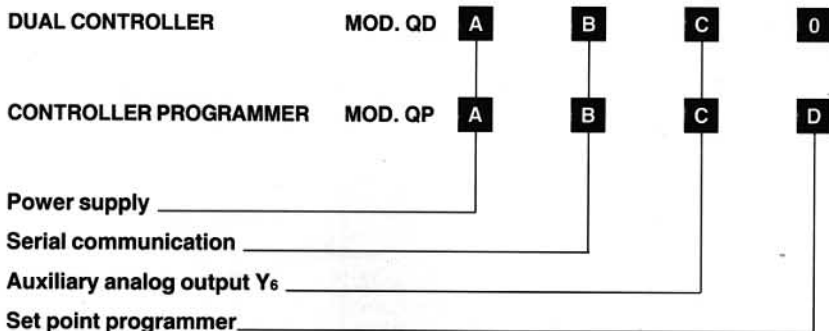

Power supply	A
100...240 Vac 50/60 Hz	3
16...28 Vac 50/60 Hz and 20...30 Vdc	5
Serial Communication (option)	B
None	0
RS485, Modbus, Jbus	3
Auxiliary analog output Y₆ (option)	C
None	0
0/4...20mA, 0/1...5V, 0...10V)	1
Set point programmer (option QP only)	D
None	0
Up to 16 programs, 255 segments	1