



REPLACEMENT FOR

- Sigma 9223
- Sigma 9263



BT033P Programmable Tri-Color Bargraph

(Class III-Commercial/Industrial Grade)

A METEK Dixon “PRO” (PROgrammable) Series bargraphs are the preferred choice for new applications, or for replacement of switchboard meters, other common size indicators, and set point controllers. The “PRO” Series is feature-enhanced, and options are available to solve most common application problems. These models are easily configurable for maximum flexibility. Class II (seismic only) and Class I (1E) versions are also available (AT033P and ST033P respectively).

Application

AMETEK Dixon bargraphs are appropriate in any application where moving pointer meters have been used in the past, and in applications where greater accuracy, readability, and reliability are desirable. The BT033P enclosure is form-factor compatible with standard, 1/8 -DIN switchboard instruments and is a direct replacement for International Sigma Model 9223 and 9263 meters. This simplifies retrofit into existing systems without panel modifications. The instruments are suitable for local or remote, primary or redundant system indication.

Signal sensitivities span ANSI C39.1 ranges, all conventional current loops, and voltage control signals. A temperature measurement option converts the instrument into a direct reading indicator using Type E, J, K, or T thermocouples, or a 100-ohm RTD. For control applications, an optional set point/relay module provides on/off and differential gap control and annunciation using three set points (LO, HI, and ALARM).

The bargraph’s color bar uses tri-color LEDs (red, amber, and green) to enhance visual resolution and readability. Standard models can be programmed to display up to four color zones. The color zones on models with the optional set point/relay module are determined by the set point placement: green for normal operation, amber for warning indications (LO or HI), and red for the ALARM indication.

The four-digit display reads to 10 percent over- and underrange. LO, HI, and ALARM annunciators are provided. The colors of the digital display and annunciators do not change and should be specified at time of order (red, amber, or green).

User-programmability provides maximum versatility and minimizes the need for spares. A solid-state design with no moving parts yields a highly reliable product, especially under conditions of shock, vibration, dust and moisture. Features such as linearization and min/max readings make the “PRO” Series the ideal choice for your application.

Features

- Brilliant tri-color LED display for excellent visibility
- Minimum 88,000-hour MTBF
- Rugged—high resistance to vibration and shock
- Digital display with true minus-sign indication
- Microprocessor-based design
- Programmable configuration using front panel switches or a PC serial link
- Available with or without program switches on front
- Input signal ranges switch-selectable
- Auto-calibration algorithm
- Linearization of input signals

- Min/max signal memory (peak/valley hold)
- Universal 1/8 -DIN form
- Front panel mounting
- Underrange/overrange indication
- Modular design for flexibility and options

Options

- Bar color transition points programmable using a PC
- On/off control using two set point relays
- Direct temperature measurement
- Horizontal mounting

BT033P Specifications

Note: for ISA S67.04 and RP67.04 Part II, consult factory for models and assistance.

PHYSICAL CHARACTERISTICS

Number of bargraph segments 33
Resolution 3.0%

ENCLOSURE MATERIAL

Metal case

DIGITAL DISPLAY OPTION

(True minus sign) -9999 to 9999

Number of digits 4
Resolution 0.01% ± 1 count*

ENVIRONMENTAL CHARACTERISTICS

Operating temperature range (MIL-E16400G, Class 4) 0 to +60° C
Storage temperature range -40 to +85° C

POWER REQUIREMENTS

115/230 VAC at 50, 60, 400 Hz

Line regulation ±10%
Power consumption (typical, depends upon options) 7.0 VA

SENSITIVITY RANGES (Reference ANSI C39.1 Std. Sensitivities)

STANDARD FULL SCALE INPUTS FROM ZERO

(DIP-switch selectable):

DC currents 500 µA to 50 mA
DC voltages 1 to 250 V

OPTIONAL FULL SCALE INPUTS FROM ZERO

DC currents - factory configured 50 µA to 250 mA
DC voltages 50 to <1000 mV
Thermocouple - Type E -100 to +1000° C
Thermocouple - Type J -18 to +760° C
Thermocouple - Type K -18 to +1370° C
Thermocouple - Type T -160 to +400° C
RTD (100-ohm platinum) -200 to +850° C

DC INPUT PARAMETERS

Linearity 0.02% of span ± 1 count*
Accuracy 0.04% of span ± 1 count*†
Zero stability <0.01% per °C
Gain stability <0.02% per °C
Input impedance:
For voltage inputs >200 k ohms
For 4 to 20 mA DC current inputs 100-ohm compliance resistor
For 10 to 50 mA DC current inputs 40-ohm compliance resistor
For all other current inputs Consult factory
Response time (typical) 175 ms
Overload (signal) 200% or 250 VDC maximum

SET POINT OPTION (internal module)

Standard set points LO and HI
Configurable alarm HI/HI (default) or LO/LO
Stability 0.1%
Hysteresis 1.0%
Relay response time (typical):
For DC inputs 350 ms
Relay contact ratings (two Form C): 0.4 A at 125 VAC
2 A at 30 VDC

LINEARIZATION

8th-order polynomial (nine terms). Refer to "PRO" Series Interface Kit.

* 1 count is defined as a ± unit value change of the right-most digit.

† Call factory for thermocouple, RTD, and square root input accuracy information.

** Except for first 5% of span.

BT033P Dimensions

Dimensions given in millimeters
(inches in parentheses)

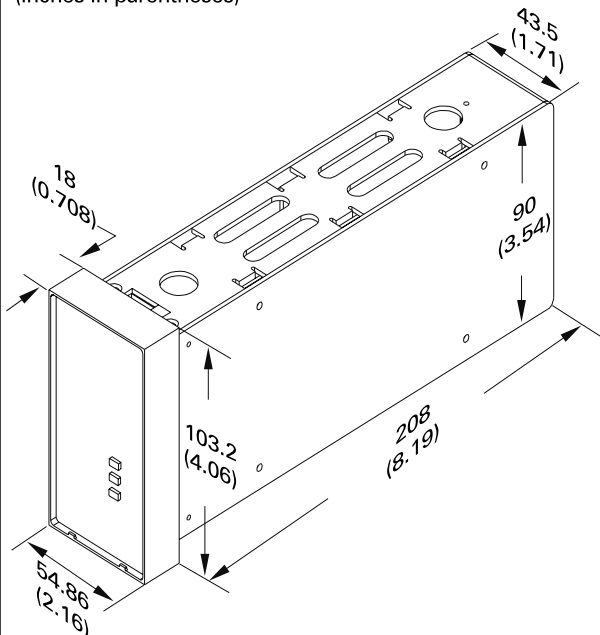

Artwork Guidelines

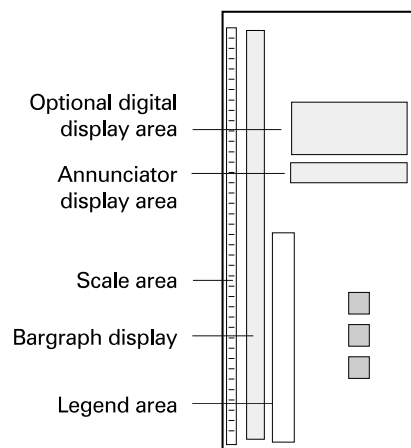

Panel Cutout Dimensions

