

*Thank you for choosing a NIVELCO instrument.  
We are sure that you will be satisfied throughout its use.*



**NIVOPOINT**  
MR-\_\_\_  
MAGNETIC FLOAT LEVEL SWITCH



## APPLICATION

The NIVOPOINT MR series of magnetic float level switches are applicable for point level switching (high or low) or for alarm (overflow, empty) in liquids.  
In case of liquids containing metal particles protect the device by using a magnetic filter.

## 2. TECHNICAL DATA

Model	MR ___	MR ___ Ex
Probe length	0,25...3 m	
Material of wetted parts	Stainless steel DIN 1.4571 / BS 316Ti)	
Max. process pressure	2,5 MPa (25 bar) (at 20°C)	
Medium density	min. 0,7g/cm <sup>3</sup>	
Medium temperature range	-40°C to +150°C	
Ambient temperature range	-40°C to +100°C	
Output	1 to 5 pcs. NO or NC reed relays	
Switching rate	120 W / VA, 250 V AC, 3 A /reed relay, max. 9 A	
Switch differential	< 10 mm	
Distance between switch points	min. 110 mm	
Electrical connection	Screw terminals in housing with Pg 16 for cables Ø7 to Ø14 mm	Screw terminals in housing with Pg 16 for cables Ø9,5 to Ø10
	Wire cross section: 0,5 to 2,5 mm <sup>2</sup>	
Process connection	1" or 2" BSP/NPT	
Sealing material	Klingerit 400	
Electrical protection	Class I.	
Mechanical protection	IP 65	
Dimension of the housing	110 x 80 x 65 mm	160 x 80 x 65 mm
Certificate for Ex versions	-	EEx d IIC T4-T6
Weight	0.4 kg + 0.3 kg/m	0.45 kg + 0.3 kg/m

## USER'S MANUAL



Manufacturer:  
**NIVELCO Process Control Co Ltd.**  
H-1043 Budapest, Dugonics u. 11.  
Tel.: (36-1)-369-7575 Fax: (36-1)-369-8585  
E-mail: [sales@nivelco.hu](mailto:sales@nivelco.hu) <http://www.nivelco.hu>

## OPERATION

A magnetic float moving alongside the protection tube tracking the level, is activating the reed relays incorporated the tube. After passing of the float, the reed relays will retain their output state.

The device is capable of direct switching a load within its specification.

## INSTALLATION

The device should be mounted in vertical position via its process connection and handled with care to avoid any damage or bend of the protection tube during transportation or installation.

After fastening, the position of the cable gland can be rotated  $\pm 180^\circ$  as well as the position of reed relays can be set  $\pm 25$ mm. Both adjustments can be done by the switch point adjustment gland, as follows:

- loosen the nut above the hexagon neck
- turn the housing as well as adjust the reed relays vertically to the required position
- tighten the nut

Use a wrench at the hexagon neck to hold the device against rotation while loosening and tightening the nut.

### **WARNING!**

**The switch point adjustment gland must not be loosened in tanks under pressure.**

## DIMENSIONS

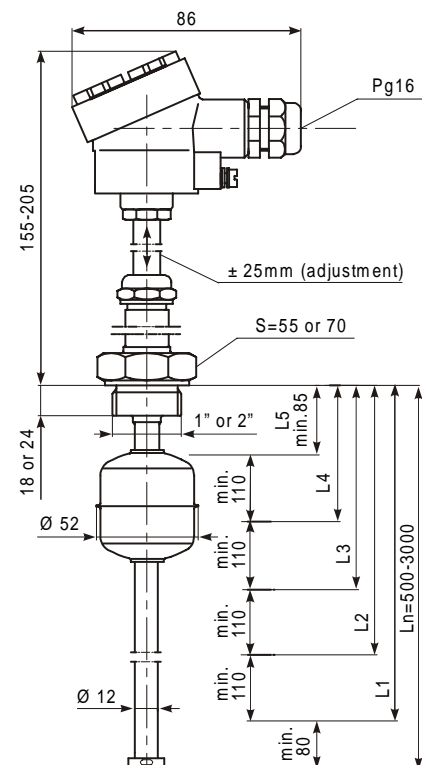

Figure 1.: Dimensions of the standard version

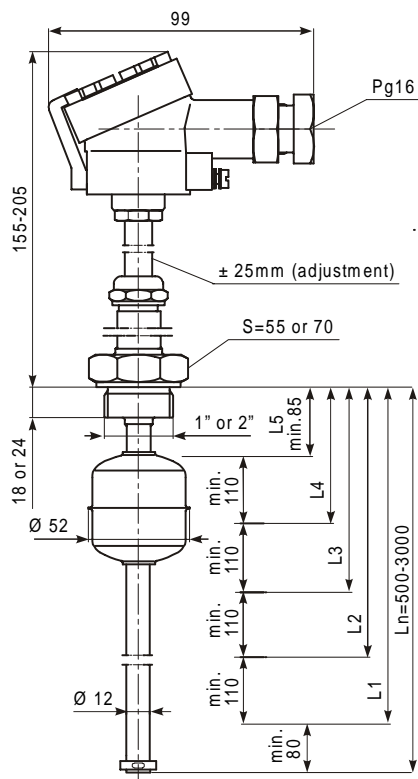

Figure 2.: Dimensions of the Ex version

The terminal of the lowest switch point has to be number by 1. „C” is common terminal.

The cross section of the connecting cable has to be between 0.5 and 2.5 mm<sup>2</sup>.

Tighten screws of the cable fixing bridge on the gland and screw up the cover. Fasten retainer clamp by setting it into one of the notch of the cover.

After replacing and fixing the cover, arrange earthing at the ground screw located on the outside of the housing.

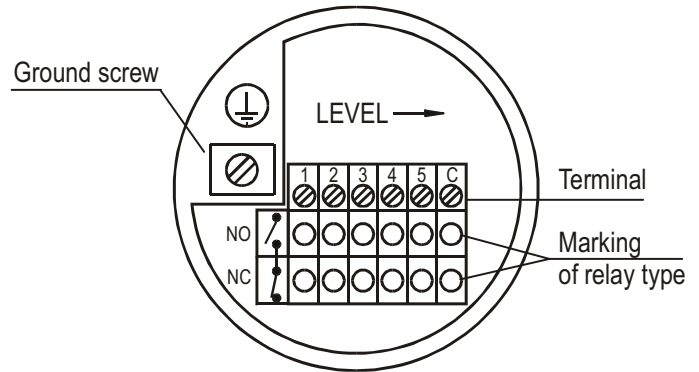
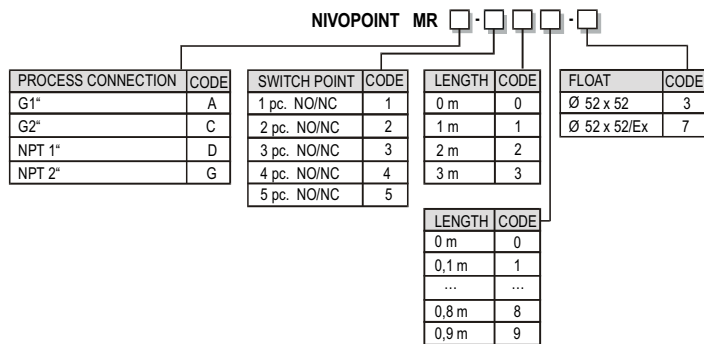

Figure 3.: Housing with removed cover

## ORDER CODE



## ELECTRICAL CONNECTIONS

### Standard model

Remove the cover, pass the wires through the cable gland and connect them in accordance with the sketch on the cover where the state (NO/NC) of the relays is marked.

The terminal of the lowest switch point has to be number by 1.

„C” is common terminal.

The cross section of the connecting cable has to be between 0.5 and 2.5 mm<sup>2</sup>.

After replacing and fixing the cover, arrange earthing at the ground screw located on the outside of the housing.

### Ex version

Remove the clamp, fixing the cover and screw down the cover. Pass the wires through the cable gland and connect them in accordance with the sketch on the cover where the state (NO/NC) of the relays is marked.

Arrange earthing. Tighten screws of the cable fixing bridge on the gland and screw up the cover.

Fasten retainer clamp by setting it into one of the notch of the cover.

## MAINTENANCE, REPAIR

The instrument does not require regular maintenance. In some instances, however, the sensor probe may need occasional cleaning to remove surface deposits. This must be carried out gently, without harming the sensor probe.

Repairs during or beyond the guarantee period are carried out solely by the manufacturer. Equipment sent back for repair should be cleaned or sterilised by the User. The User must declare that the above has been carried out.

## STORAGE CONDITIONS

Environment temperature range: -25°C to +60°C

Relative humidity: max. 98 %

## WARRANTY

All Nivelco products are warranted free of defects in materials or workmanship for a period of two years from the date of purchase.

Repairs under guarantee are carried out at the Manufacturer's premises. The Purchaser is liable for costs of dismantling and re-installation as well as transport costs.

Nivelco shall not be liable for misapplication, labour claims, direct or consequential damage or expense arising from the installation or use of equipment.