



UNICONT

PM 300 PROGRAMMABLE CONTROLLER

PROGRAMMING MANUAL



Manufacturer:

NIVELCO Process Control Co.

H-1043 Budapest, Dugonics u. 11.

Tel.: (36-1)-369-7575 Fax: (36-1)-369-8585

E-mail: sales@nivelco.hu <http://www.nivelco.com>

TABLE OF CONTENTS

| | |
|---------------------------------|----|
| 1. Register | 1 |
| 2. Instruction..... | 2 |
| 3. Order Codes..... | 3 |
| 4. Accessories..... | 3 |
| 5. Technical Data | 4 |
| 6. Operation..... | 6 |
| 7. Installation and Wiring..... | 9 |
| 8. Control algorithms | 12 |
| 9. Programming..... | 15 |
| 10. Disabling Access..... | 41 |
| 11. Auto-Line Mode..... | 42 |
| 12. Error Messages..... | 42 |
| 13. Process Control Types..... | 43 |
| 14. Data Communication..... | 48 |
| 15. Examples..... | 54 |

1. REGISTER

| | | |
|--|----------------------|----|
| Password protection: | d.PAS..... | 22 |
| Setting value | d.nni | 23 |
| Setting decimal point | C.in1 | 18 |
| Buzzer | d.HSt..... | 24 |
| Select input | C.in1 | 19 |
| Display scaling assigned to the input, low value | C.i1L | 17 |
| Display scaling assigned to the input, high value | C.i1H..... | 17 |
| Low limit value | C.SuL..... | 17 |
| High limit value | C.SuH | 17 |
| Select control function | d.Cnt | 23 |
| Cycle time | d.Yt | 22 |
| Disable/Lockout | d.nni and d.Cnt..... | 23 |
| ON/OFF control, setting relay hysteresis | d.Cnt | 23 |
| ON/OFF control, setting hysteresis value | P.dZ | 27 |
| Alarm relay function | d.AL | 26 |
| Alarm relay hysteresis position | d.AHS | 25 |
| Alarm relay value | S.A | 28 |
| Alarm relay hysteresis value | S.Ah | 28 |
| Select output analogue signal | C.out | 20 |
| Display scaling assigned to the output, low value | C.o1L | 17 |
| Display scaling assigned to the output, high value | C.o1H..... | 17 |
| Linearisation | C.uSr..... | 21 |
| Differential calculation | C.nAt..... | 21 |
| Rounding | C.nAt..... | 21 |

2. INSTRUCTION

The UNICONT PM-300 is a universal, two channel* process controller with relay and analogue outputs and PID algorithm. supporting versatile functions. It can be used from standard to extraordinary temperature control (cooling, heating) tasks. Beside the usual inputs, practically all generally used temperature sensors can be connected. Due to its auto tuning feature the controller can successfully handled by technicians unaccustomed to the process control. The dual 4-digit lighting displays allow viewing even from greater distances.

The UNICONT PM-300 is highly accurate and easy to handle, thus suitable for applications as panel instrument both in laboratory and industrial process control applications.

*(one channel for PID and the other for ON/OFF control)

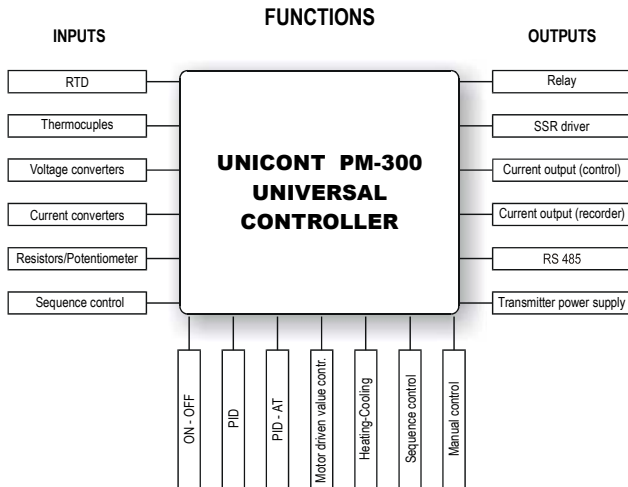

3. ORDER CODES

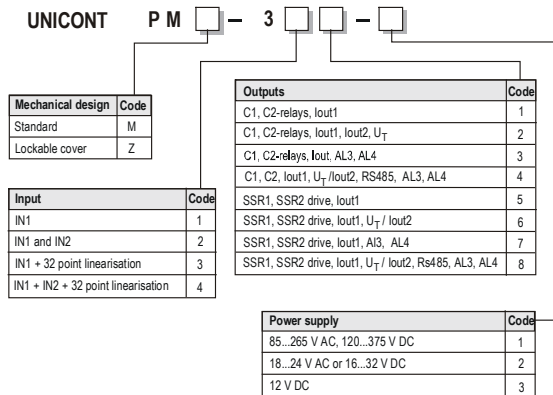

Denotation:

- IN1, IN2: Universal signal inputs
- C1/AL1, C2/A2: SPDT (Single Pole Double Throw) relay contact outputs
- AL3, AL4: SPST (Single Pole Single Throw) relay contact outputs
- SSR1, SSR2: Solid state driver output
- Iout1, Iout2: 4-20mA current output
- U_T: Transmitter power supply
- RS485: serial data communication interface with MODBUS protocol
- Linearisation: max. 32 point curve linearisation of input variable

4. ACCESSORIES

- 1 piece Programming and Installation Manual
- 2 pieces Mounting accessories
- 1 piece KTY83 for cold junction compensation of thermocouple
- 1 piece Resistor for shunting the input when configured for current (MR-25, 10 Ohm, 1%, 0.25 W, 2 pcs. for models with IN1 and IN2)
- 1 set Plug-in terminal blocks
- 1 piece Set of measurement unit stickers

5. TECHNICAL DATA

| TYPE | SEE ORDER CODES | | |
|--|--|--|------------------|
| Universal inputs (2) | Thermo-couple: K, J, T, E, L, U, N, R, S, B, M, A, C, RTD's: Pt 100, JPt 100, Pt 1000, JPt 1000, Cu 100, Ni 100 Current: 4-20 mA, 0-20 mA Voltage: -5+20 mV, 0-100 mV, 0-500 mV Resistance: 0-500 Ω , 0-2000 Ω | | |
| Input resistance | Current input: 10 Ω . Voltage input >10 M Ω | | |
| Outputs Standard version: - 2 control relays - Current output - Buzzer (Acoustic alarm) Add-ons (optional) - 2 SSR drivers - 2 Alarm relays - Second current output - Second input with diff. - Transmitter Power supp. - Data communications - 32-point linearisation | Control relays (2) | Potential free, SPDT, 250 V AC 5A (AC1) | |
| | Alarm relays (2) | SPST (NO or NC programmable), 30V DC/250V AC 3A (AC1) | |
| | SSR driver outputs (2) | 12 V DC, 15 mA | |
| | Current outputs (2) | 0/4-20 mA DC (max. load 600 ohm), galvanically isolated, short circuit protected, programmable | |
| | Power supply for transmitters | 24V DC, 100 mA, short circuit protected | |
| | RS485 MODBUS | Bit rate: 600-38400 bps (programmable) Controller address: 1 to 254 (programmable) | |
| Control algorithm ON/OFF, P, PD, PI, PID (Auto-tune) - Cooling/heating control - Control valve - 2 separate PID parameter sets - Manual valve control | Features | Setting range | Setting unit |
| | Proportional band (P) | 0.0 to 409.5% | 0.1% |
| | Integral time (I) | 0 to 4095 sec. | 1 sec. |
| | Derivative time (D) | 0 to 4095 sec. | 1 sec. |
| | Cycle time (T) | 0 to 255 sec. | 1 sec. |
| | Dead band | 0 to 255 | In PV resolution |
| | Hysteresis | 0 to 255 | In PV resolution |

| TYPE | | SEE ORDER CODES |
|------------------------------------|-------------------------------------|--|
| Display | Input signal/PV(process variable) | Upper display, red, 4 digits, 7 segments, digit height: 10 mm |
| | SV (Setpoint) | Lower display, green, 4 digits, 7 segments, digit height: 10 mm |
| | 1. control output (C1) | "C1" (orange LED) |
| | 2. control output (C2) | "C2"(orange LED) |
| | 1...4 alarm outputs | "AL1", "AL2", "AL3", "AL4" (red LED) |
| | Manual Mode | "MAN" (red LED) |
| | PV value on the display | "PV" (red LED) |
| | Control function (enabled/disabled) | "RUN" (red LED) |
| | Setpoint SV1 active | "SV1" (green LED) |
| | Setpoint SV2 active | "SV2" (green LED) |
| | Auto-tune (AT) mode | "AT" (red LED) |
| Programming | | Digital, by front panel keys |
| Accuracy of setting and displaying | | $\pm 0.2\% \text{ FS} \pm 1 \text{ digit}$ |
| Sensor wire-break Alarm | | "Er 11" on SV display (only if the controller is on) |
| Cold junction compensation | | Ext. temperature sensor to be connected to terminal block. The function can be disabled. |
| Lead resistance compensation | | 3 wire, automatic |
| Ambient moisture content | | Max .85% (relative) non condensing |
| Ambient temperature | Operational | 0°C to +55°C (+32°F to +131°F) |
| | Storage | -20°C to +60°C (- 4 °F to +140°F) |
| Power supply | | 85...265V AC, 50/60 Hz, 8 VA and 120 V...375 V DC, 8 W or 14...28 V AC, 50/60 Hz, 8 VA or 16...32 V DC, 8 W |
| Electrical connections | | Plug-in terminal blocks (use wires: 0.5 to 2.5 mm ² (3 x 0.0008 to 0.004 sq. inch) |
| Electrical protection | | Class II. |
| Standard enclosure | | Front: IP65, Rear: IP20 |
| Mounting protection | | IP54 with rubber seals ordered separately |
| Enclosure with lockable door | | Front: IP54, Rear: IP20 |
| Memory protection | | Data stored in EEPROM |
| Dimensions | | 101.5 x 48 x 160 mm (4 x 1.92 x 6.3") |
| Weight | | 0.3 kg (0.66 pound) |

6. OPERATION

The **UNICONT PM-300** Universal Controller can receive signals from transmitters, thermo-couples, RTDs, and potentiometers.

All parameters of the controller can be displayed and programmed. If error occurs, an “error message” will be shown on the “green” (PV) display.

Front panel LEDs indicate the “on status” and the operating modes of the controller, the status of the control and alarm relays and various programmed alarms. A programmed alarm can activate the controller’s own, standard built-in buzzer (alarm sound).

The **UNICONT PM-300** displays the process variable (PV) with high accuracy. Even users with little experience in process control can tune the Controller by using the “Auto-tune Mode” without need for tiresome manual setting of P, I and D parameters through several trials.

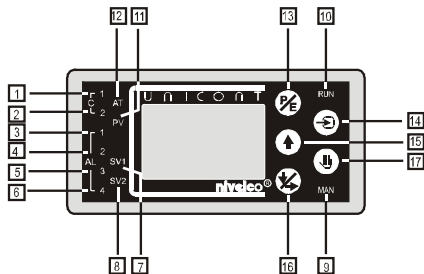

















Front panel view

On the dual-line, 4-digit display of UNICONT PM-300 both, the process variable (PV in red) and the Setpoint (SV in green) are simultaneously displayed.

Indicators LED status

- 1 — **C1:** "ON", if Relay 1. (programmed for control) is energised
- 2 — **C2:** "ON", if Relay 2. (programmed for control) is energised
- 3 — **AL1:** "ON", if Relay 1. (programmed for alarm) is energised
- 4 — **AL2:** "ON", if Relay 2. (programmed for alarm) is energised
- 5 — **AL3:** "ON", if Alarm Relay 3. is energised
- 6 — **AL4:** "ON", if Alarm Relay 4. is energised
- 7 — **SV1:** "ON", if Primary Setpoint (SV1) is displayed
- 8 — **SV2:** "ON", if Secondary (Remote) Setpoint (SV2) is displayed
- 9 — **MAN:** "ON", if Controller is in Manual Mode, SV1 display indicates the control signal (Y) in %
- 10 — **RUN:** "OFF", Idle Mode - The controller is disconnected from the process (the control is off)
"ON", Run Mode - The controller is connected to the process (the control is on)
"FLASHING", The control is performed according to the secondary (remote) Setpoint (SV2)
- 11 — **PV:** "ON", Process Variable (PV) is shown on red (upper) display
- 12 — **AT:** "ON", if the Controller is in the Auto-tune Mode
"FLASHING", the auto-tune setting is not possible because the control is off.

Function of front panel keys

| | | |
|----|---|---|
| 13 |  | Primary function: Enter Programming Mode Menus/Submenus Secondary function: Confirm flashing values and EDS* settings (ENTER) |
| 14 |  | Primary function: Change over btw. Idle Mode and Run Mode (by pressing key for 5 seconds) Secondary function: Exit Menus/Submenus Acknowledge error messages: Er4, Er5, Er6, Er7 |
| 15 |  | Primary function: Increasing the Setpoint value Scrolling Menu/Submenu points Secondary function: Increasing the displayed "flashing" value Setting the EDS* to the upper/lower position |
| 16 |  | Primary function: Decreasing the Setpoint value Secondary function: Decreasing the displayed flashing value Stepping from one EDS* to another |
| 17 |  | Primary function: Setting analogue control output (Y) to Manual Mode (press key for 15 sec) Secondary function: Resetting the latched alarms after repeated power-up |
| |  +  | Start/stop Auto-tune Mode (AT) |
| |  +  | Enable/disable access to the Definition and Calibration Tables (by pressing keys for 15 sec) -display will indicate: "SYSE" (system enabled) or "SYSd" (system disabled) |
| |  +  | Acknowledge error messages Er10 and Er11 as well as restart the controller |
| |  +  +  | Setting the Factory Default "A" Programmed for Temperature Control with PID algorithm with relay output |
| |  +  +  | Setting the Factory Default "B" Programmed for ON/OFF Control with relay output |

* EDS: Electronic Dip Switch symbolised by 8 red light bar on the display.

Rear panel view

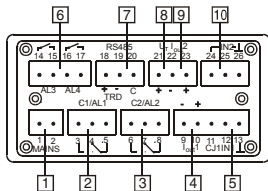

Models with relay output

- **1** — MAINS: Power supply
- **2** — C1/AL1: 1. Control/alarm relay output
- **3** — C2/AL2: 2. Control/alarm relay output
- **4** — Iout1: 1. Analogue output
- **5** — IN1: 1. Universal input

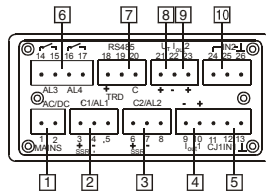

Models with SSR drive output

- **6** — AL3, AL4: 3,4. Alarm relay outputs
- **7** — RS485: RS485 interface
- **8** — U_i: Power supply for transmitters
- **9** — Iout2: 2. Analogue output
- **10** — IN2: 2. Universal input

7. INSTALLATION AND WIRING

Dimensions

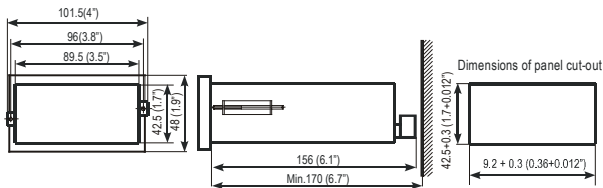

Figure 1.

Wiring

For wiring use cables of 3×0.5 to 2.5 mm^2 (3×0.0008 to 0.004 sq. inch)

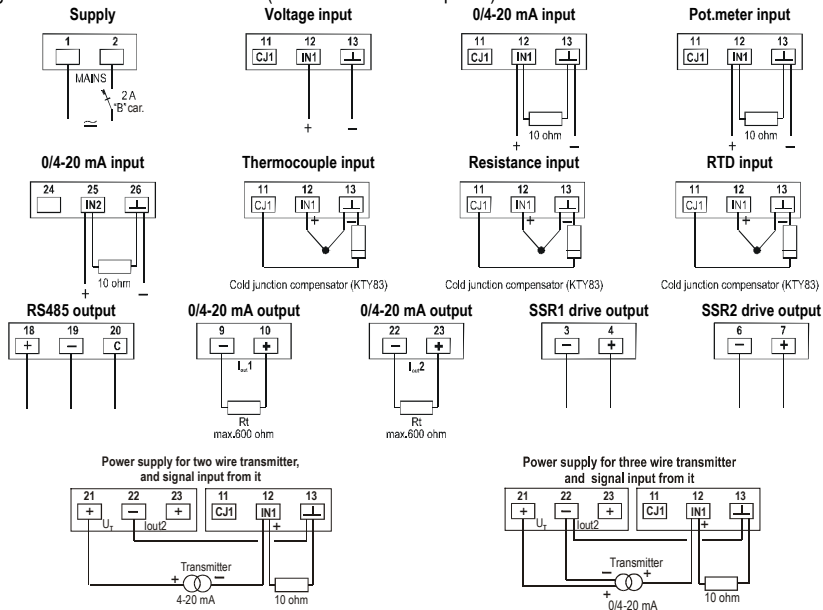

Figure 2.

Power supply (MAINS)

Connect the power supply to the **MAINS** terminals **1** and **2** with a 2-wire cable.

There is no need for protective grounding due to the dual insulation of the PM-300. For short circuit protection use a 2 A circuit breaker with "B" wire protecting characteristic. The model is internally protected by a T 315 mA fuse.

Input (IN1)

Connect the input signal (process variable "PV") as follows:

0/4-20mA current input

If the input signal is configured as a 0/4-20mA current input, connect the 10 Ohm resistor (supplied as accessory) between the terminals **12** and **13**.

Two-wire transmitters: Connect between terminals **12** and **21**.

Three-wire transmitters: Connect current output between terminals **12** and **22**
Connect (+) power supply to the terminal **21**

RTD input

RTD's are connected in a 3-wire system, using automatic wire-resistance compensation.

*If the input signal is configured as RTD input, connect the tree wires of the RTD to the terminals **11**, **12** and **13**.*

*In case of 2-wire RTD's, short-circuit the terminals **11** and **12** and use the OFFSET menu function for compensation.*

Thermocouples

If the input signal is configured as Thermocouple input, connect the Thermocouple to the terminals **12** and **13**. The KTY 83 (supplied as an accessory) for cold junction compensation should be connected between the terminals **11**, **13**.

Secondary Input (IN2)

The value of IN2 can be read-out at the menu S.in2, it can not be used for control.

Connect the secondary input signal to the terminals **25** and **26**.

For differential calculation

The secondary input can be used to calculate differential values (e.g.: two pressure transmitters for differential pressure or two level transmitters for differential level).

Remote setpoint

The secondary input is also used as a Remote Setpoint or Valve Position Feedback signal.

Current outputs (Iout1, Iout2)

Transmitter output (for re-transmitting the input signal)

The input signal (IN1) can be assigned with or without re-scaling to any of the outputs.

Control output

In general the control signal (Y) is provided by the C1 relay output or by the Iout1 current output.

The C2 relay and the Iout2 current outputs are used in case of heating-cooling processes for controlling the cooling.

The Setpoint (SV) can be assigned to any of the outputs.

Contact outputs (C1/AL1, C2/AL2, AL3, AL4)

The C1 and C2 control outputs can also be programmed for alarm functions.

Alarm functions can be assigned to the IN1 input, Setpoint (SV) or User definable events.

The controller can be programmed for two additional alarms ("AL5", "AL6"). Their physical outputs are the current outputs used as digital signal outputs to drive external contacts.

8. CONTROL ALGORITHMS

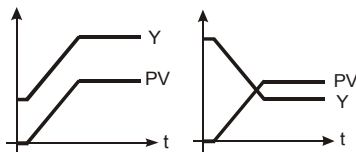

Direct algorithm

Reverse algorithm

Figure 3.

The microprocessor-based signal-processing feature makes the UNICONT PM-300 an excellent tool for a wide range of applications. It facilitates both ON-OFF and PID control applications with direct and reverse algorithm.

With direct algorithm control any increase of Process Variable (PV) will result in an increase in the output control signal (Y) (e.g.: cooling / emptying control)

With reverse algorithm control any increase of Process Variable (PV) will result in the decrease of output control signal (Y) (e.g.: heating / filling control)

ON/OFF control

It is the simplest controlling method, the output is always relay contact. The control relay will be energised or de-energised if the process variable (reference signal) goes above or below the Setpoint (SV) respectively. In order to extend the relay lifetime and avoid the chatter of the contacts a hysteresis band is assigned to the Setpoint. The hysteresis band can be symmetrical or asymmetrical. Furthermore by setting the cycle time to a value other than zero can also extend the relay lifetime.

Specify "x" in the menu P.dZ (to be set in the measuring unit of the SV)

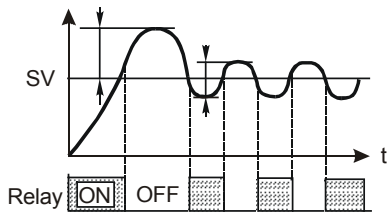

ON/OFF control without hysteresis

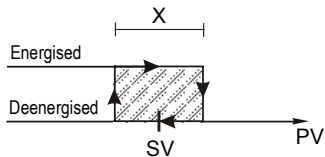

Symmetrical hysteresis band

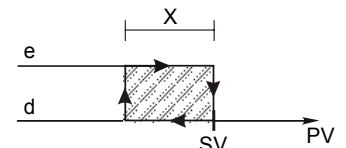

Asymmetrical hysteresis band in reverse control.
(Pump-in/Filling control)

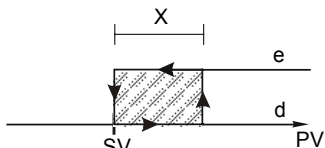

Asymmetrical hysteresis band in direct control
(Pump-out/Emptying control)

Figure 4.

PID control

The PID control mode provides more accurate control than the ON/OFF.

The PID control mode can be realised with relay contact or analogue current output. With relay contact output the PID algorithm will perform the control function by changing the energising and de-energising time within a selectable cycle time (see Figure 5). This part of the response function is called "Proportional Domain".

Proportional Band: is the domain of cyclical control mode.

Outside the Proportional Domain the control relay is permanently energised or de-energised. Cyclical control mode is effective within the Proportional Domain.

Value of Proportional Domain (p):
$$P = \frac{100}{P(\%)}$$

Where P = Proportional Gain in % entered in **P.P** and **P.cP** parameter functions

The Proportional Domain always relates to Setpoint (SV) and is positioned symmetrically to it.

*Example: If P (Proportional Gain) = 20%, then p (Proportional Domain) = 100 / 20 = 5 units
Proportional Domain: will be ± 2.5% symmetrically i.e SV=200°C means
197.5°C - 202.5°C*

Pulse Ratio: It is the pulse time per cycle time in %.

Its value depends on the control mode and the difference between the Setpoint Variable (SV) and Process Variable (PV). In case of the UNICONT PM-300, if I (Integrating Time) = 0 and D (Derivative Time) = 0, and the current value of (PV) is equal to (SV) the pulse ratio will be 50%. For PID algorithm (I ≠ 0 and D ≠ 0) these values are naturally different.

For relay output PID control the minimum (**d.YL**) and maximum (**d.YH**) of the pulse ratio should be set. Recommended values are 5% and 95% respectively.

In this case the pulse ratio is set below 5% or above 95% it will automatically change to 0% or 100% respectively

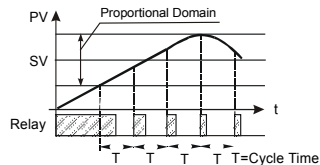

PID control with relay output

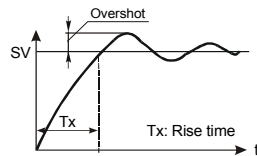

PID control with overshoot

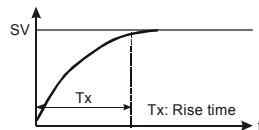

PID control without overshoot

Figure 5.



With both analogue and relay control the desired response in the process variable (PV) can be reached with or without overshoot. With overshoot the response will be achieved quicker, but sometimes the process does not endure the overshoots.

The Factory Default provides quick response and minimum overshoot (1-2%). This setting meets most requirements. For PID control without overshoot the parameter **d.trA** should be set. The default value is 50. By increasing its value the overshoot will decrease, at 80 the overshoot is practically zero. At higher values the control may involve some uncertainty, therefore each value should be checked. The Submenu point d.trA will get into the Menu (Table) by pressing the push-bottom  simultaneously with switching on the main.

9. PROGRAMMING

Operating modes

The UNICONT PM-300 has three operating modes:

- **Idle Mode:** after the first power-up, the Controller will be in Idle (Basic) Mode. Both displays (red for PV and green for SV) are active.
- **Run Mode:** the control function of the Controller is switched-on and the control outputs are active, indicated by the "RUN" LED lighting.
- **Auto-tune Mode:** the Controller automatically determines the PID settings, based upon the process characteristics. The Auto-tune Mode is indicated by the "AT" LED lighting.
 - The switch over between Idle Mode and Run Mode, press the  key for 5 seconds.
 - After repeated power-up the Controller will return to the Mode it was working in, before the power loss.
 - The Auto-tune Mode will be initiated by pressing the  and  keys simultaneously. After automatic setting of PID parameters the controller return to the RUN Mode.







Default settings

The UNICONT PM-300 has two Factory Defaults with pre-programmed parameters (for description see 8.1.).

- Factory Default A: process control oriented with PID algorithm
- Factory Default B: process indicator with limit switch

The Controller is delivered with the Factory Default A.

To change over between Factory Defaults you have to press three keys simultaneously after repeated power-up, i.e.,

- 1). Disconnect the power,
- 2). Reconnect the power and simultaneously press the following three keys simultaneously
 -  +  +  for setting Factory Default A
 -  +  +  for setting Factory Default B
- 3). Wait until the display acknowledges the change.











Programming

The programming can be initiated in all of the three operation modes.

The Controller will return to the operation mode if no keys are pressed for 30 seconds.

| Name of the Menu-points | Initials of the submenu-points |
|-------------------------|--------------------------------|
| Calibration Table | “C” |
| Definition Table | “d” |
| Parameter Table | “P” |
| Standard Table | “S” |

Access to the menu/submenu-points

- To enter the Menu (Programming Mode), press the  key. (Left-side of green display will flash).
- To scroll the Menu-points, press the  or  keys. (Initial of the actual Menu-point is flashing)
- To enter the Submenu-points, press the  key. (Right-side of green display will flash).
- To scroll the Submenu-points, press the  or  keys. (Actual Submenu-point is flashing)
- To select the Submenu-point, press the  key. (Value or EDS to be set is flashing on red display).
- To set the EDS* or value, use  or  keys.
- To confirm the setting of the EDS* or value, press the  key.
- To quit Submenu-point press  key.

*Electronic Dip Switch (symbolised by 8 red light bars on the display) – Settings:

- Red bar in the upper position = “1” (ON)

- Red bar in the lower position = “0” (OFF)

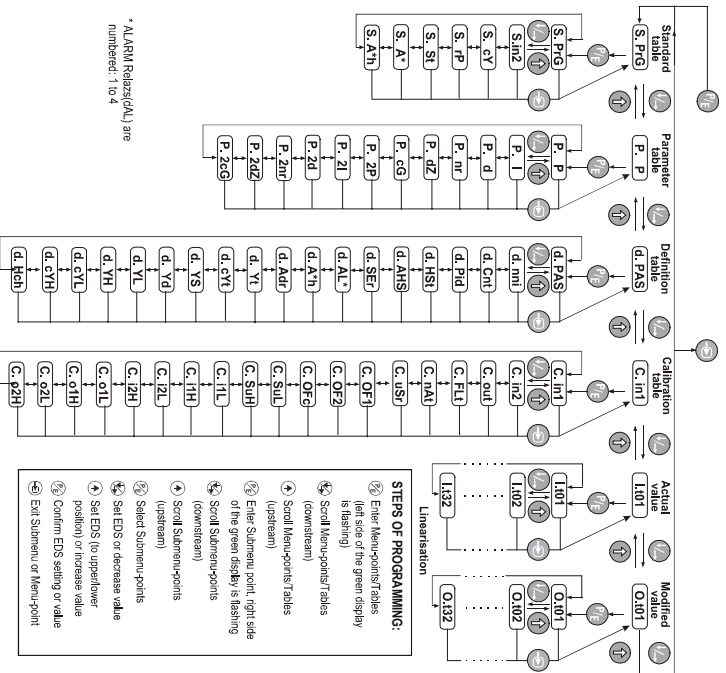

- STEPS OF PROGRAMMING:**
- ⌘ Enter Menu-points/Tables (left side of the green display is flashing)
 - ⌘ Scroll Menu-points/Tables (downstream)
 - ⬆ Scroll Menu-points/Tables (upstream)
 - ⌘ Enter Submenu point, right side of the green display is flashing
 - ⌘ Scroll Submenu-points
 - ⌘ Scroll Submenu-points (downstream)
 - ⬆ Scroll Submenu-points (upstream)
 - ⌘ Select Submenu-points
 - ⌘ Set EDS or decrease value
 - ⬆ Set EDS (to upper/lower position) or increase value
 - ⌘ Confirm EDS setting or value
 - ⌘ Exit Submenu or Menu-point

* ALARM Release(dAL) are numbered: 1 to 4

Programming flow-chart

Display during programming:

Value / submenu point



Dead zone (5°C) unit

Second PID Set

"dead band"



EDS / submenu point

EDS 00711010

9.1. FACTORY DEFAULT

Factory Default “A”

The controller is pre-programmed for temperature control with PID algorithm with relay output and parameters (EDS/value) set according to the following table:



| Description | Function/Value selection | Parameters |
|---|--|-------------------------|
| Input | Pt 100 | C.in1 : 00101110 |
| Decimal point | 999.9 | |
| Min. range (Low limit of measuring range) | 0°C | C.SuL : 0.0 |
| Max. range (High limit of measuring range) | 200°C | C.SuH : 200.0 |
| Control type | Heating (relay control, reverse algorithm) | |
| Manual overdrive mode | Enabled | d.Cnt : 01000000 |
| Cycle time | T= 20 sec | d.Yt = 20 |
| Min. relay energising time, % of cycle time | 0 % | d.YL = 0 |
| Max. relay energising time, % of cycle time | 100 % | d.YH = 100 |
| Proportional gain | 10 % | P.P = 10 |
| Integrating time | 90 sec | P.I = 90 |
| Derivative time | 20 sec | P.d = 20 |
| AL2 high alarm | Absolute value of PV1 | d.AL2 = 1000001 |
| AL2 setpoint | 200°C | S.A2 = 200.0 |
| AL2 hysteresis | Assymmetric | d.AHS = 00000000 |
| Internal buzzer (Acoustic alarm) | Enabled and assigned to AL2 | d.HSt = 01010000 |
| Current output | 4-20 mA | |
| - Range | PV signal | C.out = 00001000 |
| - Assigned to | | |
| 4 mA value | 0°C | C.o1L = 0.0 |
| 20 mA value | 200°C | C.o1H = 200.0 |
| Display settings | Roll | d.nni = 00001000 |

Modifying the Factory Default “A” (examples):

Application example #1:

- Heating/cooling control with ON/OFF algorithm
- Pt100 input
- Limit switching
- Re-transmitting the measured value (I_{OUT1})

Setpoint value (SV)

Set SV simply by the  and  keys on the front panel.

Measuring range

Set in the Menu-point *Calibration table*, at the Submenu-point C.SuL (min. range) and C.SuH (max. range).

PID parameters

To modify the factory set parameters of the PID algorithm, activate Auto-tune by pressing +  +  keys. simultaneously.

The LED “AT” is on while Auto-tune is active.

Current output (I_{OUT1})

Set in the Menu-point *Calibration table*, at the Submenu-point C.o1L (4 mA value) C.o1H (20 mA value).

Decimal point

Set on the Menu-point *Calibration table*, at the Submenu-point C.in1.

This setting influences all values programmed previously.

Alarm (AL2)

Set the value in the Menu-point *Standard table*, at the Submenu-point S.A2.

Set the hysteresis type in the Menu-point *Definition table*, at the Submenu-point d.AHS.

Set the hysteresis value in the Menu-point *Standard table*, at the Submenu-point S.A2h.

Internal buzzer (acoustic alarm)

Set in the Menu point *Definition table*, at the Submenu-point d.HSt.

Control mode

Set the ON/OFF control mode in the *Parameter table* by setting P.P= 0, P.I= 0 and P.d= 0, at the Submenu-point S.A2 (the control mode will be: ON/OFF with (lower) asymmetrical hysteresis, and Heating control).

Set the hysteresis type of the ON/OFF control in the *Definition table*, at the Submenu-point d.Cnt.

Set the hysteresis value of the ON/OFF control in the *Parameter table*, at the Submenu-point P.dZ.

To change to Cooling control: Set in the *Definition table*, at the Submenu-point d.Cnt.

Alarm (AL1)

Set the AL1 Alarm in the *Definition table*, at the Submenu-point d.Cnt. In the Factory Default "A" the relay R1 has alarm function. The setting is the same as described above under Alarm (A2).

Input signal

Set in Menu point the *Calibration table*, at the Submenu-point C.in1.



This setting influences all values programmed previously.

In case of Thermocouples, the automatic compensation is also to set. (See C.in1).

Application example #2: Setting double comparator

- Start from Factory Default A
- Inhibit PID control P.P = 0, P.I = 0, P.d = 0
- Set cycle time d.Yt = 0
- C1 relay energised under the value set
- AL2 relay energised above the value set
- Adjust C1 according to the SV
- Adjust AL2 at Submenu points S.A2 and d.AL2

Factory Default "B"

To set the Factory Default "B" disconnect the power, then press the  +  +  keys simultaneously re-connect the power and wait until the display acknowledges the change.

The controller is pre-programmed for process indicator and limit switch (input 4-20 mA) with parameters (EDS/value) set according to the following table:

| Denomination | Function/Value | EDS/Value |
|--|--|------------------------------|
| Input Position of the decimal point | 4-20mA 999.9 | C.in1 : 00111010 |
| Scaling | 4mA=0,0% 20mA=100,0% | C.i1L : 0.0 C.i1H : 100.0 |
| Operation mode | Display, 1 input | d.Cnt : 00000001 |
| AL1 alarm relay operation | Energised under the lower alarm value | d.AL1 : 00000001 |
| AL1 energised over the min value | 10% | S.A1 : 10.0 |
| AL2 alarm relay operation | Energised over the upper alarm value | d.AL2 : 10000001 |
| AL2 energised over the min value | 90% | S.A2 = 90.0 |
| Current output | 4-20mA proportional to the current input | C.out : 00001000 |
| Output value assigned to the min. input value (4 mA) | 0% | C.o1L : 0.0 |
| Output value assigned to the maxi. input value (20 mA) | 100% | C.o1H : 100.0 |
| Operation of the buzzer | in line with AL2 | d.HSt : 01010000 |
| Filtering of the input signal | medium | C.Flt : 01100000 |

- Set % value of energising relay AL1 at Submenu point S.A1
- Set % value of energising relay AL2 at Submenu point S.A2

-SETTING HYSTERESIS OF RELAY AL1

Set position of hysteresis (e.g. control of filling) at Submenu point d.AHS: (default parameter: 00000001)

Set value of hysteresis at Submenu point d.A1h e.g. 5%, d.A1h=5.0

- SETTING HYSTERESIS OF RELAY AL2

Set position of hysteresis (e.g. control of emptying) at Submenu point d.AHS: (default parameter: 00000000)

Set value of hysteresis at Submenu point d.A2h e.g. 5%, d.A2h=5.0

- SETTING BUZZER:

At Submenu point d-HSt. (default setting:00000000, out of work)

9.2 SUBMENU POINTS OF THE CALIBRATION TABLE

| Code | Description | Limit-values | Remark |
|---------------|---|----------------|--------------|
| C.in1 | Configuring the IN1 analogue input | | See Table 2. |
| C.in2 | Configuring the IN2 analogue input | | See Table 3. |
| C.out | Configuring the I _{OUT1} and I _{OUT2} analogue outputs | | See Table 4. |
| C.Flt | Setting the filtering of the IN1 and IN2 analogue inputs | | See Table 5. |
| C.nAt | Arithmetic function and rounding | | See table 6. |
| C.uSr | Choice of linearisation | | See table 7. |
| C.OF1 | Setting the offset of the IN1 analogue input | -1999...+1999 | |
| C.OF2 | Setting the offset of the IN2 analogue input | -1999...+1999 | |
| C.Ofc | Setting the cold junction compensation (OFFSET) | -1999...+1999 | |
| C. SuL | Setting the lower limit of measuring range (Min. range) If SV < SuL, display will be flashing | -1999 ...+9999 | |
| C. SuH | Setting the upper limit of meas. range (Max. range) If SV > SuH, display will be flashing | -1999 ...+9999 | |
| C.i1L | Setting the minimum value for the IN1 analogue input | -1999 ...+9999 | |
| C.i1H | Setting the maximum value for the IN1 analogue input | -1999 ...+9999 | |
| C.i2L | Setting the minimum value for the IN2 analogue input | -1999 ...+9999 | |
| C.i2H | Setting the maximum value for the IN2 analogue input | -1999 ...+9999 | |
| C.o1L | Setting the minimum value for the I _{OUT1} analogue output | -1999 ...+9999 | |
| C.o1H | Setting the maximum value for the I _{OUT1} analogue output | -1999 ...+9999 | |
| C.o2L | Setting the minimum value for the I _{OUT2} analogue output | -1999 ...+9999 | |
| C.o2H | Setting the maximum value for the I _{OUT2} analogue output | -1999 ...+9999 | |

Notes:

- Offset setting of IN1

This may be necessary in case of two-wired Pt100 to compensate the lack of the third wire:

1. Short-circuit the terminals **11** and **12**.
2. Use the Submenu point **C.OF1**. To offset the value, you may have to go through several trials while checking the 0°C (32°F) on the display using a 100 Ohm standard resistor at the place of Pt100.

- **C.out** can be configured either as a control output (Y) or to re-transmit the input signal (IN1).
 - If **C.out** is configured to re-transmit the input 0/4-20 mA signal, set 4 mA value in **C.o1L** and 20 mA value in **C.o1H**.
 - If **C.out** is configured as control output (Y), **C.o1L** and **C.o1H** must be entered in percentage, (**C.o1L** = 0% and **C.o1H** = 100% are recommended).

C.in1 Configuration of the IN1 analogue input (Table 2)

Make sure that you set decimal point (upper section of the table) and input (bottom section) as well as compensation (middle section) if applicable. (Table will continue on the next page.)

| EDS | Display | | | |
|-----------------|--------------------------------------|-------------|-------------|---|
| | Symbol | Lower value | Upper value | Resolution |
| 0 0 0 0 0 0 0 0 | No decimals | | | Place of virtual decimal point for scaleable input |
| 0 0 1 0 0 0 0 0 | 999.9 | | | |
| 0 1 0 0 0 0 0 0 | 99.99 | | | |
| 0 1 1 0 0 0 0 0 | 9.999 | | | |
| 0 0 0 0 0 0 0 0 | 0°C (32°F) base compensation | | | |
| 1 0 0 0 0 0 0 0 | Automatic cold junction compensation | | | |
| 0 0 0 0 0 0 0 0 | Not used | | | |
| 0 0 0 0 0 0 0 1 | M | -200.0 | 100.0 | 0.1 |
| 0 0 0 0 0 0 1 0 | T | -200.0 | 400.0 | 0.1 |
| 0 0 0 0 0 0 1 1 | U | -200.0 | 600.0 | 0.1 |
| 0 0 0 0 0 1 0 0 | L | -200.0 | 900.0 | 0.1 |
| 0 0 0 0 0 1 0 1 | E | 270.0 | 1000 | 0.1 |
| 0 0 0 0 0 1 1 0 | J | -270.0 | 1200 | 0.1 |
| 0 0 0 0 0 1 1 1 | N | -270.0 | 1300 | 0.1 |
| 0 0 0 0 1 0 0 0 | K | -210.0 | 1372 | 0.1 |
| 0 0 0 0 1 0 0 1 | S | -50 | 1760 | 1 |
| 0 0 0 0 1 0 1 0 | R | -50 | 1760 | 1 |

| EDS | Display | | | |
|-----------------|-------------------------|-------------|-------------|------------|
| | Symbol | Lower value | Upper value | Resolution |
| 0 0 0 0 1 0 1 1 | B | 0 | 1820 | 1 |
| 0 0 0 0 1 1 0 0 | A | 0 | 2500 | 1 |
| 0 0 0 0 1 1 0 1 | C | 0 | 2320 | 1 |
| 0 0 0 0 1 1 1 0 | Pt100 | -200.0 | 850.0 | 0.1 |
| 0 0 0 0 1 1 1 1 | JPt100 | -200.0 | 850.0 | 0.1 |
| 0 0 0 1 0 0 0 0 | Pt500 | -200.0 | 850.0 | 0.1 |
| 0 0 0 1 0 0 0 1 | JPt500 | -200.0 | 850.0 | 0.1 |
| 0 0 0 1 0 0 1 0 | Pt1000 | -200.0 | 850.0 | 0.1 |
| 0 0 0 1 0 0 1 1 | JPt1000 | -200.0 | 850.0 | 0.1 |
| 0 0 0 1 0 1 0 0 | Cu100 | -50.0 | 180.0 | 0.1 |
| 0 0 0 1 0 1 0 1 | Ni100 | -60.0 | 250.0 | 0.1 |
| 0 0 0 1 0 1 1 0 | KTY81 | -50.0 | 125.0 | 0.1 |
| 0 0 0 1 0 1 1 1 | 0...500 ohm resistance | Scaleable | Scaleable | 1 |
| 0 0 0 1 1 0 0 0 | 0...2000 ohm resistance | Scaleable | Scaleable | 1 |
| 0 0 0 1 1 0 0 1 | 0...20.00 mA | Scaleable | Scaleable | 1 |
| 0 0 0 1 1 0 1 0 | 4...20.00 mA | Scaleable | Scaleable | 1 |
| 0 0 0 1 1 0 1 1 | -5.00...20.00 mV | Scaleable | Scaleable | 1 |
| 0 0 0 1 1 1 0 0 | 0...100 mV | Scaleable | Scaleable | 1 |
| 0 0 0 1 1 1 0 1 | 0...500 mV | Scaleable | Scaleable | 1 |
| 0 0 0 1 1 1 1 0 | 0...500 ohm pot. meter | Scaleable | Scaleable | 1 |
| 0 0 0 1 1 1 1 1 | 0...2000 ohm pot.meter | Scaleable | Scaleable | 1 |

Table 2.

*Electronic Dip Switch (symbolised by 8 red light bars on the display) – Settings:

- Red light bars in the upper position = “1” (ON)
- Red light bars in the lower position = “0” (OFF)

C.in2 Configuration of the IN2 analogue input (Table 3)

Make sure that you set decimal point (upper section of the table) and input (bottom section) as will as compensation (middle section) if applicable. (Table will continues on the next page.)

| EDS | Display | | | |
|-----------------|--------------------------------|-------------|-------------|---|
| | Symbol | Lower value | Upper value | Resolution |
| 0 0 0 0 0 0 0 0 | No decimals | | | Place of virtual decimal for scaleable input |
| 0 0 1 0 0 0 0 0 | 999.9 | | | |
| 0 1 0 0 0 0 0 0 | 99.99 | | | |
| 0 1 1 0 0 0 0 0 | 9.999 | | | |
| 0 0 0 0 0 0 0 0 | Temperature is displayed in °C | | | |
| 1 0 0 0 0 0 0 0 | Temperature is displayed in °F | | | |
| 0 0 0 0 0 0 0 0 | Not used | | | |
| 0 0 0 0 0 0 0 1 | M | -200.0 | 100.0 | 0.1 |
| 0 0 0 0 0 0 1 0 | T | -200.0 | 400.0 | 0.1 |
| 0 0 0 0 0 0 1 1 | U | -200.0 | 600.0 | 0.1 |
| 0 0 0 0 0 1 0 0 | L | -200.0 | 900.0 | 0.1 |
| 0 0 0 0 0 1 0 1 | E | 270.0 | 1000 | 0.1 |
| 0 0 0 0 0 1 1 0 | J | -270.0 | 1200 | 0.1 |
| 0 0 0 0 0 1 1 1 | N | -270.0 | 1300 | 0.1 |
| 0 0 0 0 1 0 0 0 | K | -210.0 | 1372 | 0.1 |
| 0 0 0 0 1 0 0 1 | S | -50 | 1760 | 1 |
| 0 0 0 0 1 0 1 0 | R | -50 | 1760 | 1 |
| 0 0 0 0 1 0 1 1 | B | 0 | 1820 | 1 |
| 0 0 0 0 1 1 0 0 | A | 0 | 2500 | 1 |
| 0 0 0 0 1 1 0 1 | C | 0 | 2320 | 1 |
| 0 0 0 0 1 1 1 0 | Pt100 | -200.0 | 850.0 | 0.1 |

| EDS | Display | | | |
|-----------------|-------------------------|-------------|-------------|------------|
| | Symbol | Lower value | Upper value | Resolution |
| 0 0 0 0 1 1 1 1 | JPt100 | -200.0 | 850.0 | 0.1 |
| 0 0 0 1 0 0 0 0 | Pt500 | -200.0 | 850.0 | 0.1 |
| 0 0 0 1 0 0 0 1 | JPt500 | -200.0 | 850.0 | 0.1 |
| 0 0 0 1 0 0 1 0 | Pt1000 | -200.0 | 850.0 | 0.1 |
| 0 0 0 1 0 0 1 1 | JPt1000 | -200.0 | 850.0 | 0.1 |
| 0 0 0 1 0 1 0 0 | Cu100 | -50.0 | 180.0 | 0.1 |
| 0 0 0 1 0 1 0 1 | Ni100 | -60.0 | 250.0 | 0.1 |
| 0 0 0 1 0 1 1 0 | KTY81 | -50.0 | 125.0 | 0.1 |
| 0 0 0 1 0 1 1 1 | 0...500 Ohm resistance | Scaleable | Scaleable | 1 |
| 0 0 0 1 1 0 0 0 | 0...2000 Ohm resistance | Scaleable | Scaleable | 1 |
| 0 0 0 1 1 0 0 1 | 0...20.00 mA | Scaleable | Scaleable | 1 |
| 0 0 0 1 1 0 1 0 | 4...20.00 mA | Scaleable | Scaleable | 1 |
| 0 0 0 1 1 0 1 1 | -5.00...20.00 mV | Scaleable | Scaleable | 1 |
| 0 0 0 1 1 1 0 0 | 0...100 mV | Scaleable | Scaleable | 1 |
| 0 0 0 1 1 1 0 1 | 0...500 mV | Scaleable | Scaleable | 1 |
| 0 0 0 1 1 1 1 0 | 0...500 Ohm pot.meter | Scaleable | Scaleable | 1 |
| 0 0 0 1 1 1 1 1 | 0...2000 Ohm pot.meter | Scaleable | Scaleable | 1 |

Table 3.

Notes:

- The selectable °C/°F indication will apply to both IN1 and IN2.
- The automatic cold junction compensation set for IN1 applies to IN2 as well.
If the signal to IN1 does not come from a temperature sensor, there will be no cold junction, or wire compensation for IN2 either. In this case the compensation can be done by the OFFSET function.
- In case of setting follow-up control (at d.Cnt) the decimal point set at C.in1 will automatically set for C.in2.

C.out**Configuring of the analogue outputs I_{OUT1} and I_{OUT2}**

Make sure that in case of two outputs you configure both of them.

| EDS | Description | | Remark |
|-----------------|---|----------|---|
| 0 0 0 0 0 0 0 0 | Range of I _{OUT1} : 0-20 mA | Range | Configuring of analogue output signal I _{OUT1} |
| 0 0 0 0 1 0 0 0 | Range of I _{OUT1} : 4-20 mA | | |
| 0 0 0 0 0 0 0 0 | I _{OUT1} proportional to IN1 | Features | |
| 0 0 0 0 0 0 0 1 | I _{OUT1} proportional to IN2 | | |
| 0 0 0 0 0 0 1 0 | I _{OUT1} proportional to SV (control output) | | |
| 0 0 0 0 0 1 0 0 | I _{OUT1} is the control output Y1 (heating) | | |
| 0 0 0 0 0 1 0 1 | I _{OUT1} is the control output cY2 (cooling) | | |
| 0 0 0 0 0 1 1 0 | Signal from AL1 alarm relay, energised status: I _{OUT1} = 20mA | | |
| 0 0 0 0 0 1 1 1 | Signal from AL5 alarm relay, energised status: I _{OUT1} = 20mA | | |
| 0 0 0 0 0 0 0 0 | Range of I _{OUT2} : 0-20 mA | | |
| 1 0 0 0 0 0 0 0 | Range of I _{OUT2} : 4-20 mA | | |
| 0 0 0 0 0 0 0 0 | I _{OUT2} proportional to IN1 | Features | |
| 0 0 0 1 0 0 0 0 | I _{OUT2} proportional to IN2 | | |
| 0 0 1 0 0 0 0 0 | I _{OUT2} proportional to SV (control output) | | |
| 0 1 0 0 0 0 0 0 | I _{OUT2} is the control output Y1 (heating) | | |
| 0 1 0 1 0 0 0 0 | I _{OUT2} is the control output cY2 (cooling) | | |
| 0 1 1 0 0 0 0 0 | Signal from AL2 alarm relay, energised status: I _{OUT2} = 20mA | | |
| 0 1 1 1 0 0 0 0 | Signal from AL6 alarm relay, energised status: I _{OUT2} = 20mA | | |

Table 4.**Notes:**

Set both range as well as features of I_{OUT}

- In heating-cooling control applications I_{OUT1} is the heating (Y) and I_{OUT2} is the cooling (cY) control signal.
- Although the Relay 1. and 2 are configured for control (C1, C2), their internal, free programmable relays can be used as bistable alarm relays (AL1, AL2).
- The same applies for AL5 and AL6 De-energised status: 0/4 mA, Energised Status: 20 mA

C.Flt**Setting the filtering of In1 and In2 input signals**

| EDS | Description | Remark |
|-----------------|--|--------|
| 0 0 0 0 0 0 0 0 | No filtering A/D conversion optimised to mains for 50 Hz | |
| 1 0 0 0 0 0 0 0 | A/D conversion optimised to mains for 60 Hz | |
| 0 0 1 1 0 0 0 0 | Recommended value* | |
| 0 1 1 1 1 1 1 1 | The strongest (longest) filtering time (approx. 50-70 sec) | |

Table 5.

* If you are uncertain which filtering to use select this option.

C.nAt**Setting of arithmetic function and rounding**

| EDS | Description | Remark |
|-----------------|--|---------------------------------------|
| 0 0 0 0 0 0 0 0 | No arithmetic function and rounding | |
| 1 0 0 0 0 0 0 0 | Summarising function (Result value on PV display) | PV=IN1+IN2 |
| 1 1 0 0 0 0 0 0 | Summarising function (Result value on PV2 at Submenupoint S.in2) | PV2=IN1+IN2 |
| 1 0 1 0 0 0 0 0 | Differential function (IN1-IN2) | PV= IN1 - IN2 |
| 1 0 0 1 0 0 0 0 | Differential function (IN2-IN1) | PV= IN2 - IN1 |
| 1 0 0 0 1 0 0 0 | Average function (IN1+IN2)/2 | PV= (IN1+IN2)/2 |
| 0 0 0 0 0 0 0 0 | No rounding | Not depending on the decimal point |
| 0 0 0 0 0 0 0 1 | Rounding the last digit to even number | |
| 0 0 0 0 0 0 1 0 | Rounding the last digit to 0 or 5 | |
| 0 0 0 0 0 1 0 0 | Rounding the last two digits to 20-40-60-80 | |
| 0 0 0 0 0 1 0 1 | Rounding the last two digits to a number dividable by 25 | |
| 0 0 0 0 0 1 1 0 | Rounding the last two digits to a number dividable by 50 | |
| 0 0 0 0 0 1 1 1 | Rounding the last two digits to 00 | |

Table 6.**Notes:**

- Set arithmetic function according upper and rounding lower part of the table
- The arithmetic function works only in instruments with the second output (IN2), see order codes.
- The rounding effects the PV display by applying the standard rules of rounding.

| EDS | Description | Remark |
|-----------------|---|---|
| 0 0 0 0 0 0 0 0 | No linearisation | No message on the display |
| 1 0 0 0 0 0 0 0 | Linearisation operational | |
| 1 1 0 0 0 0 0 0 | Linearisation change the aggregate value of IN1 and IN2 | Display according to C.nAt |
| 1 0 1 0 0 0 0 0 | Linearisation change the scaled value of IN2 | Display at the menu function S.in2 |
| 1 0 0 1 0 0 0 0 | Linearisation change the scaled value of IN1 | Message on the PV display |
| 0 0 0 0 0 1 0 0 | The change of the second PID parameter set permitted | According to AL6 |
| 0 0 0 0 0 0 1 0 | PID parameters will slowly be defined in Auto tuning function | Overshooting decreases |
| 0 0 0 0 0 0 0 1 | Cable compensation at RTD input is cut off | |
| 0 0 0 0 1 0 0 0 | Operation is determined by AL5 | AL5 (energised) Only manual control possible |

Table 7.

Notes:

- Linearisation is only in instruments with suitable hardware configuration applicable (see order codes).
- Creation of the second PID parameter set: the change of the parameter set depends on the state of relay Alarm 6. i.e. in the de-energised state is the original parameter set, while energised the second parameter set (P.2P, P.2I, P.2d, P.2DZ, p.2cG) is valid. The change of the parameter set is independent from the existence of the relay. The second parameter set can not be used unless the change is enabled. The controller will store the results of the AT (auto-tuning) in the chosen parameter set.
- The parameters of the controlled adjustment may change depending on the process value. To provide optimal accuracy and velocity of the control process a second PID parameter set may be needed.
- In the case of control with an accuracy of 0,1 degree the cable compensation causes an uncertainty of $\pm 0,1$ degree that reduce the accuracy. In applications with short connection cables and small resistance or in 2-wire applications where the cable compensation does not make sense, the automatic cable compensation may be cut off.

9.3 SUBMENU-POINTS OF THE DEFINITIONS TABLE

| Code | Description | Limits | Remark |
|---------------|---|--------------|---------------------|
| d.PAS | Access code (4-digits). When set, the Calibration and Definition Tables can not be accessed. "0000" means there is no access code. Flashing "9999" indicates a valid access code. | 0001...8091 | |
| d.nni | Front panel functions | See Table | Table 8. |
| d.Cnt | Process control functions | See Table | Table 9. |
| d.Pid | Process control parameters | See Table | Table 10. |
| d.HSt | Internal buzzer (acoustic alarm) | See Table | Table 11. |
| d.AHS | Hysteresis type alarms relays | See Table | Table 12. |
| d. SEr | Serial data communication | See Table | Table 13. |
| d. AL* | Alarms | See Table | Table 14. -17 |
| d.A*h | Hysteresis value of alarm relays | 0.0...255 | |
| d.Adr | Controller address for serial data communication: 1...254: Slave Mode 255, or 0: No communication | 0...255 | |
| d.Yt | Cycle time/valve actuating time for relay C1 | 0...255 sec. | |
| d.cYt | Cycle time/valve actuating time for relay C2 | 0...255 sec. | |
| d.YS | Initial value of analogue valve control signal. (Effective according to the programming) | 0...100% | |
| d.Yd | Dead band for the output signal, i.e: no change at the output signal within the dead band. (Used for motor driven valve control) | 0...100% | |
| d.YL | Minimum value of I _{OUT1} | 0...100% | |
| d.YH | Maximum value of I _{OUT1} | 0...100% | |
| d.cYL | Minimum value of I _{OUT2} | 0...100% | |
| d.cYH | Maximum value of I _{OUT2} | 0...100% | |
| d.Hch | Extent of hysteresis in the heating/cooling process control | | Eng. Unit if the PV |

* Serial number of the alarm relays (AL1, AL2, AL3 and AL4), depending on the ordered configuration.

See notes to this table on next page

Notes:

- To enable/disable access to the Definition Table, press keys $\text{Ⓛ} + \text{Ⓟ}$ for more than 15 seconds. SYS.E and soon after SYS.d (disabled) is displayed. Enabling access will be performed similarly.
- In case of a relay control, irrespective of the chosen control algorithm, it is always the C1 relay that is configured as the relay control output.
Exceptions:
 1. Heating-cooling control
C1 (with reverse algorithm) is used for heating and C2 (with direct algorithm) is used for cooling
 2. Motor driven valve control
C1 is used for opening and C2 is used for closing the valve.
- The percentage value set in **d.YS** will be effective, if:
 - either the changing to Manual Mode (according to menu function **d.Cnt**) is done with this value
 - or at switching the power supply on (according to menu function **d.Pid**) the valve, starts at a percentage value defined by **d.YS** instead of 0%.
- The full opening/closing of the valve can be avoided by setting minimum (**d.YL**) and maximum (**d.YH**) limiting values for the analogue output current. Thus the full closing and opening of the valve can be avoided. Enabling may be set at the menu function **d.Pid**.

d.nni Front panel functions

| EDS | Description | Remark |
|-----------------|---|------------------------------|
| 1 0 0 0 0 0 0 0 | Disable access to front panel setting of SV1 | |
| 0 0 0 0 0 0 0 1 | Enable setting of Alarm Relay hysteresis | |
| 0 1 0 0 0 0 0 0 | Disable access to Standard Table | Disable Definition Table too |
| 0 0 1 0 0 0 0 0 | Disable the access to Parameter Table | |
| 0 0 0 1 0 0 0 0 | Disable Auto-Tuning Mode (AT) | |
| 0 0 0 0 0 0 0 0 | Display set by digits (each digit is scrolled individually) | |
| 0 0 0 0 1 0 0 0 | Display set continuously (the complete display value is scrolled) | "Roll-over" |
| 0 0 0 0 0 1 0 0 | After power failure the PM-300 goes to Idle Mode | Error code Er5 |
| 0 0 0 0 0 0 1 0 | If the Setpoint is changed while control is in progress, control will be switched off with error code Er6 | Holds last Setpoint |

Table 8.

d. Cnt

Process control functions

| EDS | Description | Remark |
|-------------------|---|---|
| 0 0 0 0 0 0 0 0 0 | Relay control (C1) with reverse algorithm for heating control | C1 energised, if $PV < SV$ |
| 0 0 0 0 0 0 0 0 1 | I_{OUT1} with reverse algorithm for heating or filling control | C1 and C2 function as alarm relays |
| 0 0 0 0 0 0 0 1 0 | Relay control for cooling (C2) / heating (C1) with 2 PID loops | Dead band should be set |
| 0 0 0 0 0 0 0 1 1 | Relay control for motor driven valves (C1 and C2 activ) | C2 interlocks C1 |
| 0 0 0 0 0 0 1 0 0 | Relay control (C1) with direct algorithm for cooling control | C1 energised, if $PV > SV$ |
| 0 0 0 0 0 0 1 0 1 | I_{OUT1} with direct algorithm for cooling or emptying control | C1 and C2 function as alarm relays |
| 0 0 0 0 0 0 1 1 0 | Analogue control for cooling / heating with PID loop. I_{OUT1} I_{OUT2} perform the control | C1 and C2 function as alarm relays |
| 0 0 0 0 0 0 0 0 0 | ON/OFF control (C1), with symmetric relay hysteresis ($P=0$, $I=0$ and $D=0$) |  |
| 0 0 0 0 1 0 0 0 0 | ON/OFF control (C1), with asymmetric relay hysteresis ($P=0$, $I=0$ and $D=0$) for heating or filling |  |
| 0 0 0 0 1 1 0 0 0 | ON/OFF control (C1), with asymmetric relay hysteresis ($P=0$, $I=0$ and $D=0$) for cooling or emptying |  |
| 0 0 0 0 0 0 0 0 0 | Control according to SV1 set on front panel | SV1, constant value control |
| 0 0 0 1 0 0 0 0 0 | Control according to IN2 analogue Setpoint value (SV2) (follow-up control, double display) | SV2 displayed in green |
| 0 0 1 1 0 0 0 0 0 | Control according to programmed Setpoint Ramp Rate and Setpoint Holding Time |  |
| 0 0 0 0 0 0 0 0 0 | Manual Mode disabled. In case of error, Idle Mode is activated | Error: failure in sensor circuit, Er11, Er12 |
| 0 1 0 0 0 0 0 0 0 | Manual Mode enabled | On the elimination of the fault, control will continue |
| 1 0 0 0 0 0 0 0 0 | In case of error, Manual Mode is activated with the last value of Y on hold | To reset, press (Ⓢ) for 10 sec |
| 1 1 0 0 0 0 0 0 0 | In case of error, Manual Mode is activated with the value set in "d.YS" | |

Table 9.

d.Pid

Process control parameters

| EDS | Description |
|-----------------|---|
| 0 0 0 0 0 0 0 1 | Reset latched Alarm. returns to "0" after activated |
| 0 0 0 0 0 0 0 0 | Sample rate of Ramp Rate Alarms set to 10 sec |
| 0 0 0 0 0 0 1 0 | Sample rate of Ramp Rate Alarms set to 100 sec |
| 0 0 0 0 0 1 0 0 | Set the control signal to the maximum value d.YS in accordance with AL5 |
| 0 0 0 0 0 0 0 0 | If control signal $Y < d.YL$ or $Y > d.YH$, it will be replaced by 0% or 100% respectively Set min. and max. values at menu functions: d.YL, d.YH, d.cYH, d.cYL |
| 0 0 0 0 1 0 0 0 | If control signal $Y < d.YL$ or $Y > d.YH_{max.}$, it will be replaced by the value in d.YL, d.YH, d.cYH, d.cYL resp. In case of analogue control, positions of the motor driven valve can be limited to values set in: d.YL, d.YH, d.cYL, d.cYH |
| 0 0 0 0 0 0 0 0 | Start of PID is "bumpless". Upon switching the power supply on the Setpoint ramps from 0.0% |
| 0 0 0 1 0 0 0 0 | Upon switching the power supply on, the PID starts from a value set in d.YS |
| 0 0 0 0 0 0 0 0 | No derivative filtering |
| 0 0 1 0 0 0 0 0 | Low derivative filtering |
| 0 1 0 0 0 0 0 0 | Medium derivative filtering (recommended) |
| 0 1 1 0 0 0 0 0 | High derivative filtering |
| 0 0 0 0 0 0 0 0 | Derivative sampling rate set to 5 sec |
| 1 0 0 0 0 0 0 0 | Derivative sampling rate set to 10 sec |

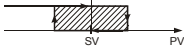
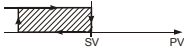
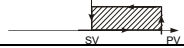
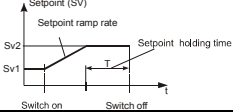
Table 10.

Note:

With relay output PID control, the pulse ratio decreases continuously. Below **d.YL** and **d.cYL**, and above **d.YH** and **d.cYH** there is no pulsing, the relay will be energised or de-energised permanently.

d.HSt**Internal buzzer (acoustic alarm)**

| EDS | Description | Remark |
|-----------------|---|---------------|
| 0 0 0 0 0 0 0 0 | Buzzer is disabled | |
| 0 1 0 0 0 0 0 0 | Buzzer operates simultaneously with AL1 | |
| 0 1 0 1 0 0 0 0 | Buzzer operates simultaneously with AL2 | |
| 0 1 1 0 0 0 0 0 | Buzzer operates simultaneously with AL3 | |
| 0 1 1 1 0 0 0 0 | Buzzer operates simultaneously with AL4 | |
| 0 0 0 0 0 0 0 1 | AL1 will be triggered after PV reaches SV1 the first time | |
| 0 0 0 0 0 0 1 0 | AL2 will be triggered after PV reaches SV1 the first time | |
| 0 0 0 0 0 1 0 0 | AL3 will be triggered after PV reaches SV1 the first time | |
| 0 0 0 0 1 0 0 0 | AL4 will be triggered after PV reaches SV1 the first time | |
| 1 0 0 0 0 0 0 0 | Buzzer will operate inverse to AL | |

Table 11.

d.AHS

Hysteresis type alarms relays

| EDS | Description | Remark |
|-----------------|---|--------|
| 0 0 0 0 0 0 0 0 | AL1 hysteresis is lower asymmetrical (Filling control) | |
| 0 0 0 0 0 0 0 1 | AL1 hysteresis is upper asymmetrical (Emptying control) | |
| 0 0 0 0 0 0 1 0 | AL1 hysteresis is symmetrical | |
| 0 0 0 0 0 0 0 0 | AL2 hysteresis is lower asymmetrical (Filling control) | |
| 0 0 0 0 0 1 0 0 | AL2 hysteresis is upper asymmetrical (Emptying control) | |
| 0 0 0 0 1 0 0 0 | AL2 hysteresis is symmetrical | |
| 0 0 0 0 0 0 0 0 | AL3 hysteresis is lower asymmetrical (Filling control) | |
| 0 0 1 1 0 0 0 0 | AL3 hysteresis is upper asymmetrical (Emptying control) | |
| 0 0 1 0 0 0 0 0 | AL3 hysteresis is symmetrical | |
| 0 0 0 0 0 0 0 0 | AL4 hysteresis is lower asymmetrical (Filling control) | |
| 0 1 0 0 0 0 0 0 | AL4 hysteresis is upper asymmetrical (Emptying control) | |
| 1 0 0 0 0 0 0 0 | AL4 hysteresis is symmetrical | |

Table 12.

Note:

The hysteresis of the relays AL5 and AL6 is always symmetric. Setting hysteresis in **S.A*h**.

d.SEr

Serial data communication

| EDS | Description |
|-----------------|--|
| 0 0 0 0 0 0 0 0 | Communication interface disabled |
| 0 0 0 0 0 0 0 1 | 600 bps |
| 0 0 0 0 0 0 1 0 | 1200 bps |
| 0 0 0 0 0 0 1 1 | 2400 bps |
| 0 0 0 0 0 1 0 0 | 4800 bps |
| 0 0 0 0 0 1 0 1 | 9600 bps |
| 0 0 0 0 0 1 1 0 | 19200 bps |
| 0 0 0 0 0 1 1 1 | 38400 bps |
| 0 0 0 0 0 0 0 0 | EVEN parity, (2 STOP bits in case CF/Seri/[4]=0) |
| 0 0 0 0 1 0 0 0 | ODD parity |
| 0 0 0 0 0 0 0 0 | Transfer without parity check |
| 0 0 0 1 0 0 0 0 | Transfer with parity check |
| 0 0 0 0 0 0 0 0 | 7 bit data communication (ASCII) |
| 0 0 1 0 0 0 0 0 | 8 bit data communication (RTU) |
| 0 1 0 0 0 0 0 0 | NA |
| 1 0 0 0 0 0 0 0 | "Broadcast" command enabled |

Table 13.

d. AL*

Alarm relays: function selection



| EDS | Description | Remark |
|-----------------|--|---|
| 0 0 0 0 0 0 0 0 | No alarm function | |
| 1 0 0 0 0 0 0 1 | HIGH Alarm (Relay: NO) Alarm is triggered if the IN1 input signal (absolute value of PV1) exceeds upper limit value | |
| 0 0 0 0 0 0 0 1 | LOW Alarm (Relay: NC) Alarm is triggered if the IN1 input signal (absolute value of PV1) exceeds lower limit value | |
| 1 0 0 0 0 0 1 0 | HIGH Alarm (Relay: NO) Alarm is triggered if PV2 value exceeds upper limit value | |
| 0 0 0 0 0 0 1 0 | LOW Alarm (Relay: NC) Alarm is triggered if PV2 value exceeds lower limit value | |
| 1 0 0 0 0 0 1 1 | HIGH alarm (Relay: NO) Alarm is triggered if SV value exceeds upper limit value | |
| 0 0 0 0 0 0 1 1 | LOW alarm (Relay: NC) Alarm is triggered if SV value exceeds lower limit value | |
| 1 0 0 0 0 1 0 1 | HIGH alarm (Relay: NC) Alarm is triggered if Y output value exceeds upper limit value | |
| 0 0 0 0 0 1 0 1 | LOW alarm (Relay: NO) Alarm is triggered if Y output value exceeds lower limit value | |
| 1 0 0 0 0 1 1 0 | HIGH alarm (Relay: NC) Alarm is triggered if cY output signal exceeding the upper limit | |
| 0 0 0 0 0 1 1 0 | LOW alarm (Relay: NO) Alarm is triggered if cY output signal exceeding the lower limit | |
| 1 0 0 0 1 0 0 1 | HIGH alarm (Relay: NC) Alarm is triggered if PV value exceeds the upper limit of Setpoint (SV) with a specified value, $AL=SV + X$ |  |
| 0 0 0 0 1 0 0 1 | LOW alarm (Relay: NO) Alarm is triggered if PV value exceeds the lower limit of Setpoint (SV) with a specified value, $AL=SV - X$ |  |
| 0 0 0 0 1 0 1 1 | WINDOW comparator, "inside window" alarm Alarm is triggered if PV1 is inside the band bordered by AL* |  |
| 1 0 0 0 1 0 1 1 | WINDOW comparator, "outside window" alarm Alarm is triggered if PV1 is outside the band bordered by AL* |  |
| 0 0 0 0 1 1 0 1 | Alarm for Ramp Rate of PV1 | Can be set in d.AL* |
| 0 0 0 0 1 1 1 0 | Alarm for Ramp Rate of PV2 | Can be set in d.AL* |
| 0 0 0 0 0 0 0 0 | Alarm function iff set as above always active | |
| 0 0 1 0 0 0 0 0 | Relay latching. Undo by manual reset only | Reset by front panel pushbutton, See d.Pid |
| 0 1 0 0 0 0 0 0 | After switching off the controller relay return to its idle position | |

Table 14.

- Serial number of the alarm relays (dAI* means AL1, AL2, AL3 AL4, AL5 and AL6), depending on the ordered configuration.
- Value of X may be set in **S.A***

d.AL* Alarms (event related)

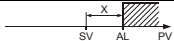
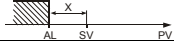
| EDS | Description | Remark |
|-----------------|--|-------------------------------|
| 0 0 0 0 1 1 1 1 | Alarm is activated upon switching on the RUN Mode | |
| 0 0 0 1 0 0 0 0 | Alarm is activated during AT (auto-tune) is in progress | |
| 0 0 0 1 0 0 1 0 | Alarm is activated during the Manual Mode | |
| 0 0 0 1 0 0 1 1 | Alarm is activated during Error | |
| 0 0 0 1 0 1 0 0 | Alarm is activated during Data communication | |
| 0 0 0 1 0 1 0 1 | Alarm is activated during the RAMP status (monitoring the Ramp Rate) | In case of programmed control |
| 0 0 0 1 0 1 1 0 | Alarm is activated during the SOAK status (monitoring the Setpoint Holding Time) | In case of programmed control |

Table 15.

- Serial number of the alarm relays (dAI* means AL1, AL2, AL3 AL4, AL5 and AL6), depending on the ordered configuration.

d.AL* Alarms (Logical relation)

| EDS | Description | Remark |
|-----------------|-------------|--------|
| 0 0 0 1 0 1 1 1 | AL1 OR AL2 | |
| 0 0 0 1 1 0 0 0 | AL1 AND AL2 | |
| 0 0 0 1 1 0 0 1 | AL1 XOR AL2 | |
| 0 0 0 1 1 0 1 0 | AL3 OR AL4 | |
| 0 0 0 1 1 0 1 1 | AL3 AND AL4 | |
| 0 0 0 1 1 1 0 0 | AL3 XOR AL4 | |

Table 16.

- Serial number of the alarm relays (dAI* means AL1, AL2, AL3 AL4, AL5 and AL6), depending on the ordered configuration.

d.AL* Logical functions

| ALARM1 ALARM3 ALARM5 | ALARM2 ALARM4 ALARM6 | AND | OR | XOR |
|----------------------------|----------------------------|-----|----|-----|
| 0 | 0 | 0 | 0 | 0 |
| 0 | 1 | 0 | 1 | 1 |
| 1 | 0 | 0 | 1 | 1 |
| 1 | 1 | 1 | 1 | 0 |

Table 17.

- Serial number of the alarm relays (dAl* means AL1, AL2, AL3 AL4, AL5 and AL6), depending on the ordered configuration.

9.4 SUBMENU-POINTS OF THE PARAMETER TABLE

| Code | Description | Range | Remark |
|--------------|--|---------------|-----------------------------|
| P.P | First PID set: Proportional Gain (P) of first control loop [%] | 0...409.5 | |
| P.I | First PID set: Integral Time (I) of first control loop [sec] | 0...4095 | |
| P.d | First PID set: Derivative Time (D) of first control loop [sec] | 0...4095 | |
| P.nr | First PID set: "Manual reset" value of first control loop. (The Setpoint is virtually offset by this value) | -1999...+1999 | Active if P.I = 0 |
| P.dZ | First PID set: "Dead band" for heating-cooling control or motor driven valve applications. Hysteresis value for ON-Off control (P.P=0, P.I=0, P.d=0) | 0...255 | |
| P.cG | First PID set: Power Ratio* of the control device | 0.1...100 | |
| P.2P | Second PID set: Proportional Gain (P) of first control loop [%] | 0.0...409.5 | |
| P.2I | Second PID set: Integral Time (I) of second control loop [sec] | 0...4095 | |
| P.2d | Second PID set: Derivative Time (D) of second control loop [sec] | 0...4095 | |
| P.2nr | Second PID set: "Manual reset" value of second control loop. | -1999...+1999 | |
| P.2dZ | Second PID set: "Dead band" | -1999...+1999 | |
| P.2cG | Second PID set: Power Ratio | 0.1...100 | |

Note:

* Efficient power ratio of the heating-cooling control devices.

Notes:

- There are two sets of PID parameters available for setting but only one of them is operable (either Set 1 or Set 2)
- Using AT (auto-tune) the P, D and I parameters are automatically set.

9.5 SUBMENU-POINTS OF THE STANDARD TABLE

| Code | Description | Range | Remark |
|--------------|--|---------------|-----------|
| S.PrG | Software revision number | | |
| S.in2 | Value of second input (In2) | | Read only |
| S.cY | Output signal value of the second control loop for heating-cooling control. Can be changed only in Manual Mode | 0...100% | |
| S.rP | Ramp Rate value in Ramp Rate control | -1999...+9999 | unit/hour |
| S.St | <p>“Holding Time” of Setpoint after the Setpoint is reached.</p> <p>If the operator try to change the Setpoint during holding time the result (will be according to the last two rows of “d.nni” see page 22)</p> <ul style="list-style-type: none"> - either error signal “Er6”, - or control according to the changed Setpoint | 0...4095 | Minute |
| S.A* | Alarm values | Based on PV | |
| S.A*h | Alarm hysteresis | 0...255 | |

* Serial number of the alarm relays (AL1, AL2, AL3, AL4, AL5 and AL6), depending on the ordered configuration.

Notes:

- The hysteresis values of alarms can also be set in the Menu point *Definition Table*.
- The signal value of the second input (IN2) can be read-out in Submenu point “**S.in2**” e.g. in motor driven valve control, if the position-detecting potentiometer is connected to IN2, the valve position can be read-out in the Submenu point “**S.in2**”.

10. DISABLING ACCESS

Access for programming the UNICONT PM-300 can be enabled/disabled:

- by an access code,
- by setting the Submenu point “d.nni” in the Menu point *Definition Table*
- via front panel keys

a). Access lock with access code

The access code can be set between 0001 and 8091 in the Submenu “d.PAS” at the *Definition Table*.

If access is disabled by an access code, programming of the *Definition* and *Calibration Tables* is denied, however it does not affect the access to the *Parameter and Standard Tables*.

If access is disabled by an access code, “9999” will be displayed at the Submenu point “d.PAS”.



To enable access, the value “9999” must be overwritten by the access code.

To delete the access code, after entering the access code, “0000” must be entered.



b). Access locks set in the Submenu point “d.nni”

| EDS | Description | Remark |
|-----------------|--|--|
| 1 0 0 0 0 0 0 0 | Disable settings of SV1 by front panel keys | |
| 0 0 0 0 0 0 0 1 | Disable settings of the alarm relay's hysteresis | |
| 0 1 0 0 0 0 0 0 | Disable settings of the Standard Table | Disabling the Definition Table also required |
| 0 0 1 0 0 0 0 0 | Disable settings of the Parameter Table | |
| 0 0 0 1 0 0 0 0 | Disable settings of Auto-Tune function | |

c). Access lock set by the front panel keys

To enable/disable access to the Definition Table, press the  and  keys for 15 seconds.

11. AUTO-LINE MODE

- 1). Set the UNICONT PM-300 to RUN Mode (after it has been programmed)
- 2). Press the  +  keys to set the AT Mode.

In AT Mode the Controller starts from the initial position, then - after three “forced” overshots - it will return to the programmed Setpoint. The size of the “forced” overshots may be as large as 50% of the Setpoint. If this may do damage your process, reduce the Setpoint to 30-50% of its original value for the time of Auto-tune operation.

The time of Auto-tune operation can be between 0.1 to 3 hours, depending on the process. After reaching the Setpoint several times, the Auto-tune Mode will automatically stop and the AT indicator LED will go out.









The automatically set PID parameters can be read-out on the display (Parameter Table).

The UNICONT PM-300 can also operate with its default PID parameters.

Due to the probable several forced overshots, the technological process may be distorted during the Autotune Mode.

12. ERROR MESSAGES

In case of faulty setting or operation error code (Er) will appear on the SV display.

| Error message | Description | Remark |
|---------------|--|---|
| Er 1 | Set value(e.g. SV) is outside the measuring range | Er 1 will be on display for 3 seconds |
| Er 4 | Configuration error | Acknowledge with  key |
| Er 5 | Mains power failure | Acknowledge with  key |
| Er 6 | Unauthorised setting of Setpoint See Submenu point “d.nni” | Acknowledge with  key |
| Er 7 | Program is deleted: Re-programming is required | Acknowledge with  key |
| Er 10 | Fault at the input, inverse connection | Acknowledge with  +  keys |
| Er 11 | Connection to sensor is broken | Acknowledge with  +  keys |

The error message Er 10 and Er 11 can also be acknowledged by switching off and on the power supply. Should the fault not be repaired, the error message will re-appear on the PV display after 2 minutes. Er11 will only be displayed in RUN Mode and with manual control enabled.

In case of other error messages contact the supplier.

13. PROCESS CONTROL TYPES

The UNICONT PM-300 supports the following control types

Constant value control

Follow-up control

Heating-cooling Control

Programmed-Control System

The UNICONT PM-300 is suitable for the special tasks

Motor Driven Valve Control

Manual Valve Control

Linearisation

Calculation of level difference

Constant value control

The Controller is keeping the Setpoint value, set on the SV display constant.

Follow-up control

The control is performed by keeping the Process variable (PV), received at In1., at the same value as the changing Setpoint value (SV), received at In2. As far as operation is concerned, the follow-up control is similar to the constant value control with remote value setting. The only difference is that the remote value will only be set time by time, while the SV (sent by an on site SV-transmitter, 0...20mA) of the follow-up control is changing.

Heating-cooling control

Heating-cooling control is an analogue control method for keeping the temperature at a set value by activating the cooler or heater respectively. To achieve this, one PID control loops and two outputs (relay or analogue) are provided. The PID parameter set is free programmable. During the process control the parameters may be changed over automatically.

A neutral (dead) zone of optional extent can be set both with relay or analogue output. In the control signal within the neutral zone the output signal does not change. The neutral zone can be set in the Submenu point **P.dz**.

In process controls with relay output hysteresis can be dedicated to both relays. This hysteresis is symmetric and can be set at the Submenu point **d.HCh**, see **Figure 6**.

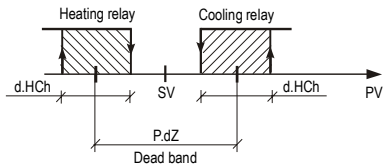

Figure 6.

Tasks, similar to cooling-heating can be solved with the controller, such as neutralisation of wastewater (titration).

Programmed Control

In case of Programmed Control, the SV will be reached with a ramp rate, set at Submenu point **S.rP**. The SV will be kept constant for the time, set at Submenu point **S.St**, and the control will be switched off.

If the SV cannot be reached because of an incorrect value entered, the controller will skip the ramp phase.

The ramp rate: unit of SV/h

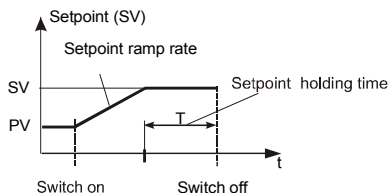

Figure 7.

After repeated power-up, the control will be continued from the actual process variable (PV)

- is the PV under the value of SV, the control will be continued with the same ramp rate. The Setpoint Holding Time will start at the time the Setpoint is reached.
 - is the PV of the same value as SV, the count down of the Setpoint holding time will continue from the point of interruption.
- The status of program can be indicated by alarm relays. (See Submenu point **d.AL***). The RAMP status will correspond to the "Ramp Phase" and the SOAK status to the "Setpoint Holding Phase".

Should the Setpoint be modified during the active control process, operation will be performed according to the setting of the Submenu point "**d.nni**": either the control will be switched off with error code "**Er6**" or the control will be performed in accordance with the new Setpoint. The timing will not change.

Motor Driven Valve Control

For the control of a motor driven valve the PID control loop is used with two relays: C1 for opening and C2 for closing the valve. The relay C2 operates in inverse mode: normally closed and open at the request for closing the valve. The C2 LED being "ON" indicate the closing of the valve.

For connecting the motor driven valve see figure below.

The "**dead band**", meeting the application requirements, can be set at the Submenu point "**P.dZ**".

Valve control can be performed with either ON-OFF or PID algorithm.

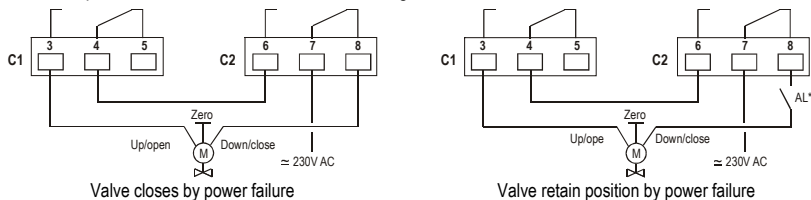

Figure 8.

There is no need for valve position feedback for the control. If the valve position signal is available, connect it to In2, and the valve position can be read on SV display.

The valve position signal on input In2 can only be read, it has no influence on the process variable (PV).

PID control of valves

The following parameters (amongst others) should be set:

d.Yt "Run Time" of valve. (Time needed for fully open the valve from fully closed status)

d.Yd Dead-Band of "Actuating Signal" of the valve (Y). (in % of the Run Time.)

In case of PID control the Actuating Signal will always change, even if the desired position is reached. The oscillation of the Actuating Signal can be up to 1-2%.

Without Dead Band the Actuating Signal would keep the valve in a continuous opening/closing motion. This usually does not improve the accuracy of the control, but decreases the lifetime of the valve dramatically.

To overcome this problem for example by setting **d.Yd** to 3%, the controller will operate the valve only if the change in "Actuating Signal" (Y) is bigger than 3%.

d.YL and **d.YH** These parameters are used as with the relay control mode.

P.dZ Determines the width of the input dead band that is symmetrical to SV. If the PV is within this band, there will be no "Error Signal", therefore the PID controller is assuming that the correct Actuating Signal has been found.

The **d.Yd** and **P.dZ** values can only be optimised by several trials.

ON/OFF control of valve

For ON-OFF control, **P.P= 0** should be set. The hysteresis can be set at **P.dZ**. In this case the motor driven valve can only be in the two end-positions (fully open or fully closed) and the Actuating Signal is permanently applied to the valve.



Three-position control of valves

Choosing heating-cooling algorithm, setting the parameter **P.P=0** a three-position control will be achieved, where the neutral zone is set at the Submenu point **P.dZ** and the hysteresis of the switches at **d.HCh**.



Manual setting of motor driven valves

Motor driven valves with analogue input (0/4-20 mA) can also be remote controlled manually.

To switch over to Manual Mode, press the "Manual"  key for 5 seconds, the message "MAN" will be on the display and the valve control signal (Actuating Signal) will be displayed in percentage on the SV display.

To increase/decrease the valve control signal (Actuating Signal), press  and  keys respectively.

In case of failure, switching over to Manual Mode is carried out according to the setting of the parameter at the Submenu point "**d.Cnt**" (either holding last valid output control signal (Y) or with the parameter set at **d.YS**. Failure of the controller is

indicated by the alarm relay and the operator can manually control the process by changing the output control signal (Y) with  and  keys.

Calculation of level difference (differential level metering) or average

This function is valid only if the controller has two inputs (IN1 and IN2).

To use this function, proceed as follows:

- 1). Scale the IN1 and IN2 inputs at the Submenu **C.i1L** and **C.i1H**, as well as **C.i2L** and **C.i2H**.
- 2). Select a function (arithmetic function , subtraction, calculating average) at the Submenu **C.nAt**.

Linearisation

Linearisation will be needed if the relation between the measured value and the displayed value is not linear. This non-linear function can be approached by a series of data-pairs. This makes possible for instance to display the volume of the medium in a horizontal cylindrical tank by measuring the level.

The UNICONT PM-33_ and the PM-34_ can perform a linearisation of 32 data-pairs

To set the linearisation, proceed as follows:

Setting linearisation

- 1). Select the function of linearisation at the Submenu **C.uSr**
- 2). Scale the appropriate input(s) (IN1, IN2) at the Submenus **C.i1L** and **C.i1H** (**C.i2L** and **C.i2H**).
- 3). Select enabling linearisation and set modifiable analogue signal at Submenu-point C.uSr.
- 4). Enter data-pairs at the Submenu-point I.t01 and O.t01

NOTE

The measured values and the values to be displayed have to be entered at the Submenu-point I.txx (in the measurement units of the input) and Submenu-point O.txx (in the measurement unit of the output) respectively. For example: should the value at the Submenu-point I.t01 be 15 and the value at the Submenu-point O.t01 be 18, this means that with the input signal reaching 15 the value of 18 will be displayed.

The 32 point-pairs can be entered in optional order with the constraint that increasing values of I.txx must come with increasing values of O.txx

14. DATA COMMUNICATION

The UNICONT PM-300 can be interconnected with other Controllers (such as computer or another PM-300) equipped with RS485 interface. The Controller uses MODBUS data communications protocol. For details see the “PI-MBUS-300 Rev B Gould Modbus Protocol Reference guide”

The UNICONT PM-300 supports both Serial Transmission Modes: RTU and ASCII.

| Data bits | Protocol |
|-----------|--------------|
| 7 | MODBUS ASCII |
| 8 | MODBUS RTU |

The data communication parameters can be set in the Submenu points **d.SEr** and **d.Adr** of the Menu point *Definition Table* “d.” (see section 8.2.).

The parameters of the data communication interface are configurable (bit rate, parity, 7/8 bit data).

Is the Controller address set to values between 1 and 254, it will operate as Slave.

Is an address set to ‘0’, the Controller is closed out from the communication

The UNICONT PM-300 is VISION 4 compatible.

Protocol functions:

| | | |
|----|---------------------------|-------------------------------|
| 04 | Read input register | Reading of registers and MENU |
| 06 | Pre-set single register | Writing of registers and MENU |
| 16 | Pre-set multiple register | Writing of SV |

Error messages:

| | | |
|----|----------------------|------------------------------|
| 01 | Illegal function | Not used function code |
| 02 | Illegal data address | Not used address or register |
| 03 | Illegal data value | Incorrect value |

Explanation of abbreviations used in the following tables:

| Abbreviation | Description |
|---------------------|--|
| B | Can be sent as a broadcast command |
| M | Accessible for multiple writing (function 10H) (the data always has two words) |
| R | Accessible for reading |
| W | Accessible for writing |
| 2 | Two word reading |
| bit | FF00= 1 or 0000= 0 (no other value is valid) |
| EDS | 00 Where: = EDS |
| DP | The decimal points are according to address 0x980 |

The data communications are interpreted according to MODBUS default: HI byte is first, LOW byte is last in a single word (16 bit) data.

With two word data the controller follows the above procedure. First the most significant bit is transmitted followed by the less significant ones.

| Addr. | Abbr. | Data | Description |
|--------|--------------|-----------------|--|
| 0x100 | B, M, R/W, 2 | SV/10 (4 byte) | Setpoint*10 (tenfold value), SV is interpreted in 0.1 UNIT |
| 0x140 | R, 2 | PV/10 (4 byte) | Process Variable (In1)/10 (the value is integer but interpreted in decimals) |
| 0x142 | R, 2 | PV2/10 (4 byte) | Process Variable of In2 (interpreted as above) |
| 0x146 | R, 2 | CJ/10 (4 byte) | Cold Junction Compensation value (interpreted as above) |
| 0x200 | R/W | SV | Setpoint (SP) seen on display, DP |
| 0x210 | R/W | Y/10 | Actuating Signal (can be modified only in Manual Mode) |
| 0x220 | R | PV | Process Variable (PV) seen on display, DP |
| 0x230 | R | PV2 | Secondary Process Variable (PV2) seen on display, DP |
| 0x2FE | R | | Type of controller ("Hi" byte), version number ("Lo" byte) |
| 0x2FF | R | | Error code (1 to 15) (least significant 4 bits of "Lo" byte) |
| 0x800 | B, R/W, bit | | Start/stop On/Off control |
| 0x801 | R/W, bit | | Control mode (Switching over between Manual and Automatic Mode) |
| 0x802 | R/W, bit | | Enable/Disable of access to the controller |
| 0x803 | R/W, bit | | Enable AT (Auto Tune) |
| 0x804 | R, bit | | AT in progress |
| 0x900 | R | | Relay status (Hi byte) and One-Shot status(Lo byte) |
| 0xF00 | W, bit | | Reset Error |
| 0xF01 | W, bit | | Reset "Alarm One-Shot" |
| 0xF02 | W, bit | | Keyboard disable (the front panel keys are disabled for ~30sec) |
| 0xFFFF | W, bit | | Restart controller |

Addresses above 1000 are for the Menu points of the Controller.

For the accessibility the same rules apply as described with the Front panel functions (See page 22). (Functions and values inaccessible by front panel keys are also inaccessible over the serial interface) The ranges of values to be set via serial interface are also the same as those to be set by front panel keys.

| Address | Abbr. | Data | Description |
|---------|-------|-------|--|
| 0x1000 | R | S.PrG | Controller hardware versions and software version number |
| 0x1001 | R | S.in2 | DP |
| 0x1002 | R | S.1-2 | DP |
| 0x1003 | R | S. rP | |
| 0x1004 | R | S. St | |
| 0x1005 | R/W | S. A1 | |
| 0x1006 | R/W | S. A2 | |
| 0x1007 | R/W | S. A3 | |
| 0x1008 | R/W | S. A4 | |
| 0x1009 | R/W | S.Ah1 | |
| 0x100A | R/W | S.Ah2 | |
| 0x100B | R/W | S.Ah3 | |
| 0x100C | R/W | S.Ah4 | |
| 0x1100 | R/W | P. P | |
| 0x1101 | R/W | P. I | |
| 0x1102 | R/W | P. d | |
| 0x1103 | R/W | P. nr | |
| 0x1104 | R/W | P.dZ | |
| 0x1105 | R/W | P. cG | |
| 0x1106 | R/W | P. 2P | |
| 0x1107 | R/W | P. 2l | |
| 0x1108 | R/W | P.2d | |
| 0x1109 | R/W | P.2nr | |
| 0x1110 | R/W | P.2dZ | |
| 0x1111 | R/W | P.2cG | |
| 0x1200 | R/W | d.PAS | 0000...8192 |
| 0x1201 | R/W | d.nni | EDS |

| Address | Abbr. | Data | Description |
|---------|-------|-------|---|
| 0x1202 | R/W | d.Cnt | EDS |
| 0x1203 | R/W | d.Pid | EDS |
| 0x1204 | R/W | d.HSt | EDS |
| 0x1205 | R/W | d.AHS | EDS |
| 0x1206 | R/W | d.Ser | EDS |
| 0x1207 | R/W | dAL1 | EDS |
| 0x1208 | R/W | dAL2 | EDS |
| 0x1209 | R/W | dAL3 | EDS |
| 0x120A | R/W | dAL4 | EDS |
| 0x120B | R/W | AL1h | 0...255 or 0.0...25.5 (depending on DP) |
| 0x120C | R/W | AL2h | 0...255 or 0.0...25.5 (depending on DP) |
| 0x120D | R/W | AL3h | 0...255 or 0.0...25.5 (depending on DP) |
| 0x120E | R/W | AL4h | 0...255 or 0.0...25.5 (depending on DP) |
| 0x120F | R/W | d.Adr | 0...255 |
| 0x1210 | R/W | d. Yt | 0...255 |
| 0x1211 | R/W | d.cYt | 0...255 |
| 0x1212 | R/W | d.trA | 0...100 |
| 0x1213 | R/W | d. YS | 0...100 |
| 0x1214 | R/W | d. Yd | 0...100 |
| 0x1215 | R/W | d. YL | 0...100 |
| 0x1216 | R/W | d. YH | 0...100 |
| 0x1217 | R/W | d.cYL | 0...100 |
| 0x1218 | R/W | d.cYH | 0...100 |
| 0x1219 | R/W | d.HCH | 0...100 |
| 0x1300 | R/W | C.in1 | EDS |
| 0x1301 | R/W | C.in2 | EDS |
| 0x1302 | R/W | C.out | EDS |

| Address | Abbr. | Data | Description |
|---------|-------|-------|--|
| 0x1303 | R/W | C.FLt | EDS |
| 0x1304 | R/W | C.nAt | EDS |
| 0x1305 | R/W | C.uSr | EDS |
| 0x1306 | R/W | C.Co1 | -1999...+1999 |
| 0x1307 | R/W | C.Co2 | -1999...+1999 |
| 0x1308 | R/W | C.Gn | -1999...+1999 |
| 0x1309 | R/W | C.CGn | -1999...+1999 |
| 0x1310 | R/W | C.OF1 | -1999...+1999 |
| 0x1311 | R/W | C.OFc | -1999...+1999 |
| 0x130A | R/W | C.OF2 | -1999...+1999 |
| 0x130B | R/W | C.SuL | -1999...+9999 or -199.9...+999.9 (depending on DP) |
| 0x130C | R/W | C.SuH | -1999...+9999 or -199.9...+999.9 (depending on DP) |
| 0x130D | R/W | C.i1L | -1999...+9999 |
| 0x130E | R/W | C.i1H | -1999...+9999 |
| 0x130F | R/W | C.i2L | -1999...+9999 |
| 0x1310 | R/W | C.i2H | -1999...+9999 |
| 0x1311 | R/W | C.o1L | -1999...+9999 or -199.9...+999.9 (depending on DP) |
| 0x1312 | R/W | C.o1H | -1999...+9999 or -199.9...+999.9 (depending on DP) |
| 0x1313 | R/W | C.o2L | -1999...+9999 or -199.9...+999.9 (depending on DP) |
| 0x1314 | R/W | C.o2H | -1999...+9999 or -199.9...+999.9 (depending on DP) |

To enable programming via the serial interface, when programming via front panel keys is disabled, send a Write command to address 0xF02 which will disable front panel keys for a period of 30 seconds. This can be extended by repeated the writing of this address. During this period the various protections can be enabled/disabled. For detailed information about enabling/disabling the access see Section 8.2.

The controller chooses the decimals concerning the PV, SV and the ALARMS according to the configuration.

15. EXAMPLES

EXAMPLE 1

Input: Temperature Sensor – Output:
ON-OFF relay

| | |
|---------------|--|
| C. in1 | Configuring the input and setting the places of the decimal points |
| C. SuL | Set lower limit of the measuring range |
| C. SuH | Set upper limit of the measuring range |
| d. Cnt | Selecting the type of control |
| d. Yt | Set cycle time (recommended: 15 sec.) |
| d.YL | Set min. pulse ratio within cycle time (recommended: 0%) |
| d.YH | Set max. pulse ratio within cycle time (recommended: 100%) |
| P.P | Select ON/OFF control mode (P=0) |
| P. dz | Set hysteresis value of ON/OFF control |
| SV1 | Set the Setpoint |
| RUN | Start control process |

EXAMPLE 2

Input: Temperature Sensor – Output:
PID relay

| | |
|---------------|--|
| C. in1 | Configuring the input and setting places of decimals |
| C. SuL | Entering the lower limit of measuring range |
| C. SuH | Entering the upper limit of measuring range |
| d. Cnt | Selecting the type of control |
| d. Yt | Entering the cycle time (recommended :15 sec.) |
| d.YL | Entering the min. pulse ratio within cycle time (recommended: 5%) |
| d.YH | Entering the max. pulse ratio within cycle time (recommended: 95%) |
| d.Pid | Entering the derivative filtering time and sampling rate |
| d.trA | Entering the value of first overshoot (recommended: 50%) |
| SV1 | Entering the Setpoint |
| AT | Setting the PID parameters in Auto-tune Mode (AT) |
| RUN | Starting the control process |

EXAMPLE 3

**Input: Analogue Signal – Output:
PID Analogue Control Signal**

| | |
|---------------|--|
| C. in1 | Configuring the input and setting places of decimals |
| C. SuL | Entering the lower limit of measuring range |
| C. SuH | Entering the upper limit of measuring range |
| C.i1L | Entering the value belonging to minimum input signal |
| C.i1H | Entering the value belonging to maximum input signal |
| C.FLt | Entering the input filtering time |
| C.out | Configuring the analogue output |
| C.o1L | Entering the value belonging to minimum output signal |
| C.o1H | Entering the value belonging to maximum output signal |
| d.Cnt | Selecting the type of control |
| d.YL | Entering the minimum of analogue output signal (recommended: 0%) |
| d.YH | Entering the maximum of analogue output signal (recommended: 100%) |
| d.Pid | Entering the derivative filtering time and sampling rate |
| d.trA | Entering the value of first overshoot (recommended: 50%) |
| SV1 | Entering the Setpoint |
| AT | Setting the PID parameters in Auto-tune Mode (AT) |
| RUN | Starting the control process |

EXAMPLE 4

**Input: Pt100 – Output PID relay with
programmed control algorithm**

| | |
|---------------|--|
| C. in1 | Configuring the input and setting places of decimals |
| C. SuL | Entering the lower limit of measuring range |
| C. SuH | Entering the upper limit of measuring range |
| d. Cnt | Selecting the type of control |
| d. Yt | Entering the cycle time (recommended: 15 sec.) |
| d.YL | Entering the min. pulse ratio within cycle time (recommended: 5%) |
| d.YH | Entering the max. pulse ratio within cycle time (recommended: 95%) |
| d.Pid | Entering the derivative filtering time and sampling rate |
| SV1 | Entering the Setpoint |
| AT | Setting the PID parameters in Auto-tune Mode (AT) |
| S.rP | Setting the Ramp Rate |
| S.St | Setting the Setpoint Holding Time |
| RUN | Starting the control process |

EXAMPLE 5

**Input: Temperature Sensor – Output:
PID relays for motor driven valve**

| | |
|---------------|--|
| C. in1 | Configuring the input and setting places of decimals |
| C. SuL | Entering the lower limit of measuring range |
| C. SuH | Entering the upper limit of measuring range |
| d. Cnt | Selecting the type of control |
| d. Yt | Entering the cycle time (is equal to the Run Time of Valve.) |
| d.YL | Entering the min. pulse ratio within cycle time (recommended: 5%) |
| d.YH | Entering the max. pulse ratio within cycle time (recommended: 95%) |
| d.Pid | Entering the derivative filtering time and sampling rate |
| P.dz | Entering the value of Dead Band |
| SV1 | Entering the Setpoint |
| AT | Setting the PID parameters in Auto-tune Mode (AT) |
| RUN | Starting the control process |

EXAMPLE 6

Setting the Alarms

| | |
|--------------|--|
| d.AL* | Setting the operation mode of alarm relays |
| d.AHS | Setting the hysteresis type of alarm relays |
| d.Hst | Setting the first operation mode of alarm relays |
| S.A* | Setting the triggering value of alarm relays |
| S.A*h | Setting the hysteresis value of alarm relays |

* Serial number of the alarm relays (AL1, AL2, AL3 and AL4), depending on the ordered configuration.

pmm3111m0606p_01
March, 2001