



# NIVOCONT R-300/R-400

VIBRATION ROD LEVEL SWITCHES

## TYPICAL APPLICATIONS

### Plastic processing:

*powders, pellets, granulates*

### Chemical industries:

*powders, pills, crystals*

### Agriculture/Food industries:

*grains, rice, cereals, feed, flour*

### Paper and Pulp industries:

*crushed cellulose, shavings*

### Recycling:

*paper cuts, ground plastic*

### Power generation:

*fly ash, lime, carbon black*

### Mining and quarry:

*coal, stone powder*

### Construction:

*cement, sand, clay*



- ◆ Single probe design: no clogging!
- ◆ Various output versions:
  - 3-wire solid state output
  - power relay with SPDT
- ◆ High temperature versions up to 160°C
- ◆ Fine polished sensing probe as standard
- ◆ Visible status indication
- ◆ Plastic or Aluminium housing
- ◆ Power supply: two ranges cover all requirements
- ◆ 'Dust Ex' certificate, also for the cable extended version!

## GENERAL

Advantages such as robustness, self-cleaning for most mediums by vibration, pressure and corrosion resistance offered by vibration rods make them the optimal solution for single point level switching in free flowing solids. Correct installation promises a low-cost, reliable and long-life level detection in bins and silos containing bulk materials.

Applied to granular materials lump size must not exceed 10 mm. Only mediums with sufficient internal friction can be detected.

If applied as low level switch, utmost care should be taken to prevent damaging the probe by the pressure of the medium.

The vibration rod is a mechanical resonant system excited and kept in resonance by an electronic circuit. When covered by material the damping of the vibration will be detected by the electronic which, after a built in time delay initiate the switching of the output relay.

The electronics using highly reliable SMT components is completely potted, eliminating environmental impacts such as moisture, vibration etc.

## MODEL SELECTION

### Standard length

Used for high failsafe in bins or for hopper low failsafe

### Pipe extended

Can be used for both high or low failsafe. If used for low failsafe in mediums of great internal friction, consider that the moving medium may bend and damage the probe.

### Cable extended

Usually used for both high or low failsafe. Can not be used with mediums of large granular size. Abrasive mediums may damage the cable.

### Custom extended

Advantageously applied if switching point can not be determined in advance. Extension pipe (max. 2m) has to be supplied / manufactured by the customer.

# INSTALLATION

- Determining mounting location the caving or arching of the material should be considered.
- Cable extended version for low-level alarm is suggested to mount above the outlet of the tank/silo.
- Side mounted device in powder applications should be installed with an inclination exceeding the angle of repose, to enable efficient self-cleaning of the rod.
- Avoid mounting device in a recess.
- Prior to the installation, it is advised to test the switching function of the unit on a sample quantity of material and to set "Density" switch according to the density of medium.
- Screw in the device by its hexagon neck. After screwing tight the process connection, the housing can be rotated (max. 300°), to adjust the cable glands to the required position.

	High level	Low level*
Standard	Side mount	Side or bottom mount
Pipe extended	Top mount	Side or bottom mount
Cable extended	Top mount	Top mount

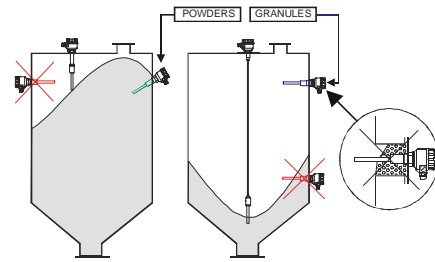

\* The NIVOCONT is not suggested to be used for low level detection in high density materials

- Limits for bending or pulling force and torque should be considered.

Standard	Pipe extended	Cable extended
F = 445 N (M = 85 Nm)	—	F = 45 kN
	M = 85 Nm	—

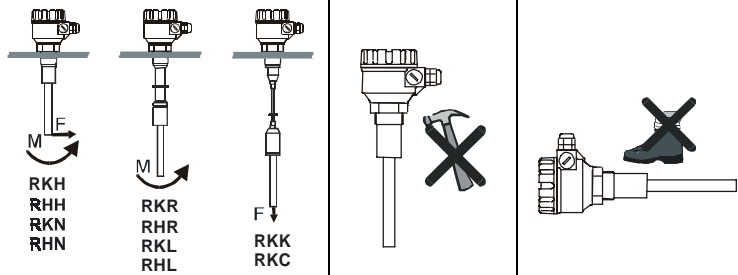

- Handle the device with great care, especially the sensing probe. A larger impact on the sensing probe may ruin its resonance system.
- Probes exposed to falling material or mechanical loads should be protected.

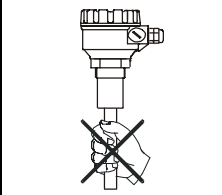
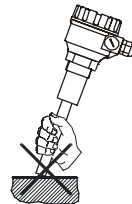
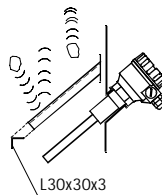

# SETTING UP TO THE PROCESS

Adjustment will be carried out by three switches by selecting (high/low) fail-safe mode, switching delay and density.

## HIGH/LOW fail-safe mode (Switch C)

- De-energised status of the relay or open state of solid state output is preferred to be used for fail-safe alarm, thus a power breakdown will also be considered as alarm (see Operation diagram).

## Time delay (Switch B)

- Standard (switching delay: approx. 5 sec) or fast response (switching delay: approx. 2 sec) can be selected.

## DENSITY (Sensitivity) adjustment (Switch A)

- LOW position, recommended for loose and light materials with density around and below 0.1 kg/dm<sup>3</sup> represents low energy and amplitude of vibration as well as great sensitivity of detection.
- HIGH position, recommended for (thick and heavy) materials with density over 0.1 kg/dm<sup>3</sup> represents vibration with high energy and amplitude and small sensitivity of detection.

# DIMENSIONS

Standard version

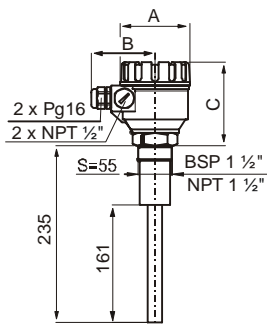

	A	B	C
R-300	100	89	120
R-400	93	89	118

Pipe extended version

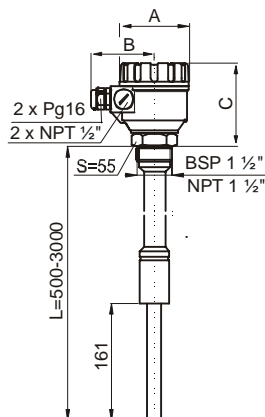

Cable extended version

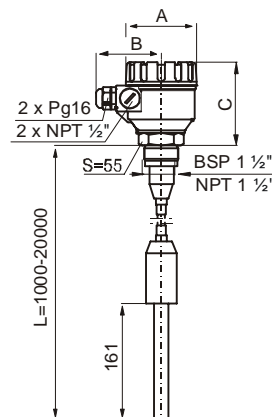

Custom extended version

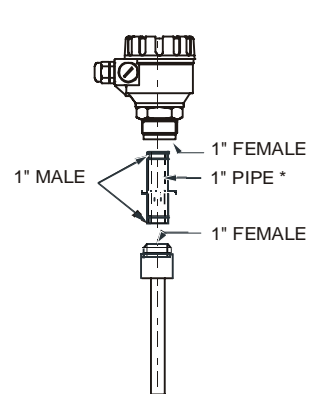

\* max. 2m possible

# ELECTRICAL CONNECTION

Relay output version

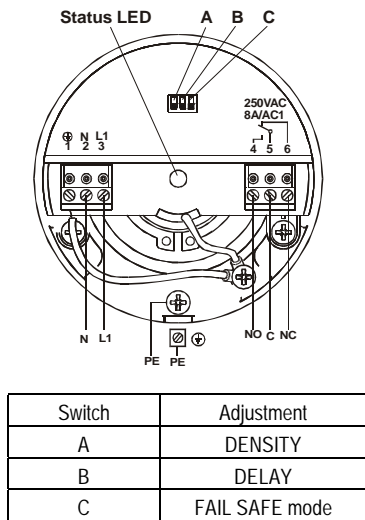

Solid state output version

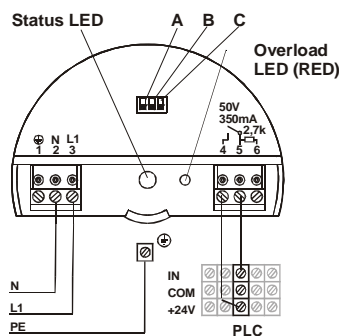

Electrical connection of a optocoupled sink input

Operation diagram

Power	Probe	Fail-safe mode	Status LED	RELAY	SOLID STATE OUTPUT
On	Not vibrating (covered)	LOW	GREEN	5-4 6-6 Energised	6-2.7k 4-5 ON
		HIGH	RED	5-4 6-6 De-energised	6-2.7k 4-5 OFF
	Vibrating (free)	LOW	RED	5-4 6-6 De-energised	6-2.7k 4-5 OFF
		HIGH	GREEN	5-4 6-6 Energised	6-2.7k 4-5 ON
Fails	-	LOW or HIGH	NOT LIT	5-4 6-6 De-energised	6-2.7k 4-5 OFF

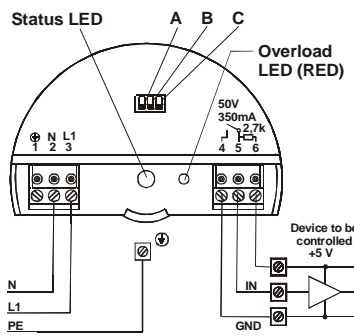

Electrical connection of a logical voltage input

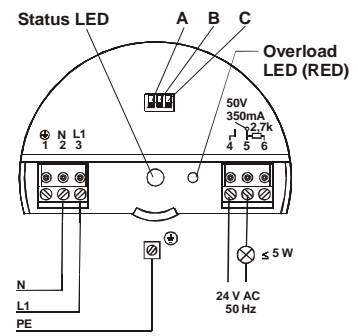

Electrical connection of a load

# TECHNICAL DATA

## General specification

Model	Standard		Pipe extended	Cable extended
	RKH, RKN, RHH, RHN		RKR, RKL, RHR, RHL RKE, RKF, RHE, RHF	RKK, RKC
Probe length	235 mm		0.3 to 3 m	1 to 20 m
Parts protruding into tank	1.4571 (SS316Ti)			Probe: 1.4571 (SS316Ti) Cable: PE coated
Housing material	Aluminium: Powder paint coated (R-300 series) Plastic: PBT fibre-glass reinforced, flame-retardant (DuPont®) (R-400 series)			
Process connection	1 1/2" BSP or 1 1/2" NPT (see Dimensions)			
Temperature ranges see Derating diagram	Process	RK: -30 °C to +110 °C, RH: -30 °C to +160 °C		-25 °C to +90 °C
	Ambient temp.	-30°C to +60 °C		
Max. pressure (absolute)	25 bar (2.5 MPa)		6 bar (0.6 MPa)	
Minimum medium density*	0.05 kg/dm <sup>3</sup> (max. granular size: 10 mm)			
Response time (selectable)	When covered	< 1.8 sec or 5 ±1.5 sec		
	When free	< 2 sec or 5 ±1.5 sec		
Supply voltage	Voltage version I: 16...40V AC (50/60Hz) / 19...55V DC Voltage version II: 85...265V AC (50/60Hz) / 120...375V DC			
Power consumption	Voltage version I: ≤ 2.5 VA, 1.2 W Voltage version II: ≤ 2.5 VA, 1.3 W			
Electrical connections	2x Pg16 for Ø8 to 15 mm cables and 2 x 1/2" NPT; max. 1.5 mm <sup>2</sup> wire cross section			
Mechanical protection	IP67 (NEMA6)			
Electrical protection	Class I. (to be grounded)			
Explosion proof protection mark	Ex II D I T6 IP67 (Zone 20) ** (except RKE, RHE, RKF, RHF and versions in plastic housing)			
Max. mechanical load on rod	F = 445 N (M = 85 Nm)	M = 85 Nm		F = 45 kN
Weight (with extension)	plastic housing	156 kg		1.56 kg (+ 0.6 kg/m)
	aluminium housing	1.94 kg		1.94 kg (+ 0.6 kg/m)

\* may depend on friction and granular size of the medium

\*\* Pending



## Output versions

Version	Relay	Solid state
	R00-000-1 R00-000-2 R00-000-5 R00-000-6	SPDT (potential free) 250 V AC, 8A, AC 1
Output	SPDT (potential free)	SPST (electronic/isolated)
Output rating	250 V AC, 8A, AC 1	350 mA/50V peak
Output protection	—	Overvoltage, overcurrent and overload protection
Voltage drop (switched of state)	—	< 1.7 V 350 mA
Residual current (switched on state)	—	< 10 µA

## Derating diagram

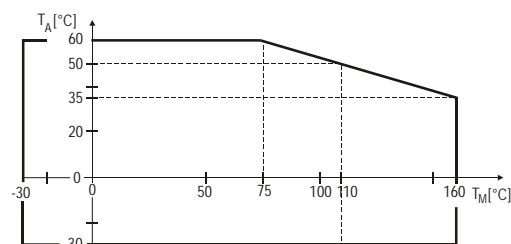

Ambient temperature ( $T_A$ ) versus medium temperature ( $T_M$ )

## ORDER CODES

### STANDARD VERSION

NIVOCONT R   -  0 2 -

VERSION	CODE	PROCESS CONNECTION	CODE	HOUSING	CODE	SUPPLY / OUTPUT	CODE
Standard	K	1 ½ " BSP	H	Alu. cast	3	85-265 V AC / 120-375 V DC / relay	1
High temp.	H	1 ½ " NPT	N	Plastic	4	16-40 V AC / 19-55 V DC / relay	2
						85-265 V AC / 120-375 V DC / solid state	3
						16-40 V AC / 19-55 V DC / solid state	4
						85-265 V AC / 120-375 V DC / relay / Dust Ex	5
						16-40 V AC / 19-55 V DC / relay / Dust Ex	6
						85-265 V AC / 120-375 V DC / solid state / Dust Ex	7
						16-40 V AC / 19-55 V DC / solid state / Dust Ex	8

### PIPE EXTENDED VERSION

NIVOCONT R   -    -

VERSION	CODE	PROCESS CONNECTION	CODE	HOUSING	CODE	LENGTH	CODE	SUPPLY / OUTPUT	CODE
Standard	K	1 ½ " BSP	R	Alu. cast	3	0.5 to 3 m	05 to 30	85-265 V AC / 120-375 V DC / relay	1
High temp.	H	1 ½ " NPT	L	Plastic	4			16-40 V AC / 19-55 V DC / relay	2
								85-265 V AC / 120-375 V DC / solid state	3
								16-40 V AC / 19-55 V DC / solid state	4
								85-265 V AC / 120-375 V DC / relay / Dust Ex	5
								16-40 V AC / 19-55 V DC / relay / Dust Ex	6
								85-265 V AC / 120-375 V DC / solid state / Dust Ex	7
								16-40 V AC / 19-55 V DC / solid state / Dust Ex	8

### CABLE EXTENDED VERSION

NIVOCONT R K    -

PROCESS CONNECTION	CODE	HOUSING	CODE	LENGTH	CODE	SUPPLY / OUTPUT	CODE
1 ½ " BSP	K	Alu. cast	3	0.5 to 3 m	05 to 30	85-265 V AC / 120-375 V DC / relay	1
1 ½ " NPT	C	Plastic	4			16-40 V AC / 19-55 V DC / relay	2
						85-265 V AC / 120-375 V DC / solid state	3
						16-40 V AC / 19-55 V DC / solid state	4
						85-265 V AC / 120-375 V DC / relay / Dust Ex	5
						16-40 V AC / 19-55 V DC / relay / Dust Ex	6
						85-265 V AC / 120-375 V DC / solid state / Dust Ex	7
						16-40 V AC / 19-55 V DC / solid state / Dust Ex	8

### CUSTOM EXTENDED VERSION

NIVOCONT R   -  0 2 -

VERSION	CODE	PROCESS CONNECTION	CODE	HOUSING	CODE	SUPPLY / OUTPUT	CODE
Standard	K	1 ½ " BSP	E	Alu. cast	3	85-265 V AC / 120-375 V DC / relay	1
High temp.	H	1 ½ " NPT	F	Plastic	4	16-40 V AC / 19-55 V DC / relay	2
						85-265 V AC / 120-375 V DC / solid state	3
						16-40 V AC / 19-55 V DC / solid state	4

Technical specification may be changed without notice.

**NIVELCO PROCESS CONTROL CO.**

H-1043 BUDAPEST, DUGONICS U. 11.

TEL.: (36-1) 369-7575 • FAX: (36-1) 369-8585

E-mail: sales@nivelco.hu http://www.nivelco.com